



4" SAND FIGHTER SUBMERSIBLE MOTORS

SINGLE-PHASE 2-5 HP & THREE-PHASE 3-10 HP

APPLICATIONS

These motors are built for superior dependability in 4" diameter or larger sandy water wells.

SAND FIGHTER™ MOTOR FEATURES

- Corrosion-Resistant Construction
- Stainless Steel Splined Shaft

FEATURES

- Single-phase 230 V 60 Hz
- Three-phase 200 V, 230 V, 380 V, 575 V 60 Hz, 460/380 V 60/50 Hz
- Corrosion-Resistant Construction
- Stainless Steel Splined Shaft
- 3 & 5 hp High Thrust are built using the advanced Power-Dense 24-slot stator to maximize available horsepower per linear inch of motor length
- Hermetically-Sealed Windings
- Anti-Track Self-Healing Resin System
- Water Lubricated Bearings
- Filter Check Valve
- Kingsbury-type Thrust Bearing rated for 1500 lbs downthrust
- Pressure Equalizing Diaphragm
- Built-in Lightning Arrestors (single-phase)
- Removable Water-Bloc Lead
- NEMA Pump Mounting Dimensions
- UL 778 Recognized
- CSA C22.2 #108 Certified
- Temperature and time rating continuous in 86 °F (30 °C) water at 1/4 ft per second flow past motor
- Single-phase rotation, CCW; three-phase, electrically reversible

CONTROL BOXES

- Franklin's single-phase submersible Control Boxes are suitable for outdoor mounting with operation over temperature ranges of +14 °F (-10 °C) to +122 °F (50 °C)
- Start and run winding overloads protect the motor from failure due to abnormal operating conditions
- Available in 3 and 5 hp ratings, the DELUXE Control Box incorporates a magnetic line contactor to eliminate the need for auxiliary contactors and heavy duty pressure switches
- A heavy duty terminal strip with box type lugs makes it easy to install up to #2 AWG wire
- Ground lugs provide a means of grounding the motor and Control Box to the power supply ground in compliance with NEC and other national and local codes

WARNING: Serious or fatal electrical shock or fire hazard may result from failure to follow the instructions for proper installation and use which accompany this equipment. Do not use motor in swimming areas.



4" SAND FIGHTER SUBMERSIBLE MOTORS

AVAILABILITY

Single-phase Capacitor Start, Capacitor Run (Control Box Required)

HP	KW	"L" Dim Inches	Shipping Weight	
			LBS	KG
2	1.5	19.2	42	20
3	2.2	22.49	47	21
5	3.7	27.41	64	29

Three-phase, 60 Hz - 3450 RPM (50 Hz - 2875 RPM)

HP	KW	"L" Dim Inches	Shipping Weight	
			LBS	KG
3	2.2	19.44	41	19
5	3.7	22.49	50	23
7.5	5.5	27.41	64	29
10	7.5	30.48	72	33

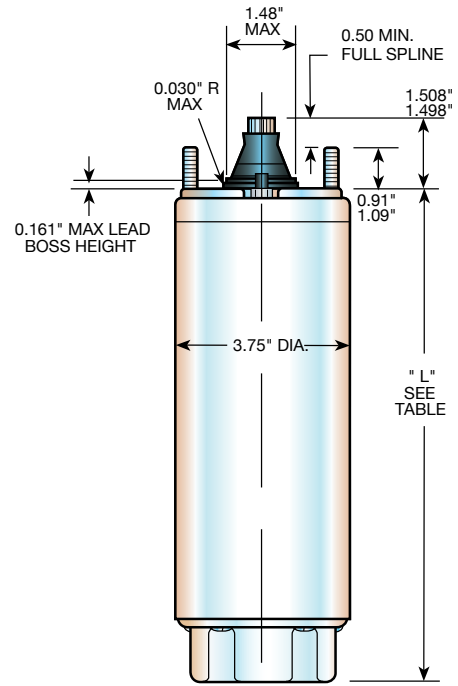

CONSTRUCTION MATERIALS

Component	Standard Water Well
1 Top Casting	304 SS
2 Bottom Casting	303 SS Over Painted Cast Iron
3 Stator Shell	301 SS
4 Stator Ends	Low Carbon Steel
5 Shaft Extension	17-4 SS on 5 - 10 hp
6 Fasteners	300 Series SS
7 Seal Cover	Sintered Bronze
8 Seal	Sand Fighter™ SiC/SiC Mech Seal
9 Diaphragm	Nitrile Rubber
10 Diaphragm Plate	304 SS
11 Diaphragm Spring	302 SS
12 Diaphragm Cover	304 SS
13 Slinger	Nitrile Rubber
14 Lead Wire (or Cable)	XLPE ^①
15 Lead Potting	Epoxy
16 Lead Clamp	300 Series SS
17 Filter	Delrin & Polyester

* Removable type leads installed. Consult the Franklin Electric Technical Service Hotline at 800.348.2420 for information regarding replacement leads. Specifications subject to change without notice. Contact Franklin Electric if current material types are required for bid specifications.