

FPS



50 Hz 141STS SERIES Submersible Turbine Pumps

FEATURES

- Premium ductile iron casting for longer life and higher pressures
- Longer discharge and motor bracket bearings for increased pump life
- Spiral cutlass rubber intermediate bearings designed for abrasive environments
- 416 stainless steel pump shaft ground and polished for maximum durability
- Investment cast stainless steel impellers for maximum abrasion resistance
- Custom pumps available

SPECIFICATIONS

- 8" 141 m³/h

MODEL NO. EXPLANATION

Example: 42STS11D8B-0366

- 42 = Flow series m³/h
- STS = Series (Sub Turbine)
- 11 = Motor kW (9.3)
- D = Ductile iron
- 8 = Pump diameter (8")
- B = Impeller trim configuration
- 03 = Number of stages
- 6 = Motor size (6")
- 6 = Discharge size (6")



50 Hz 141STS SERIES Submersible Turbine Pumps

PERFORMANCE - 8" 141 M³/H

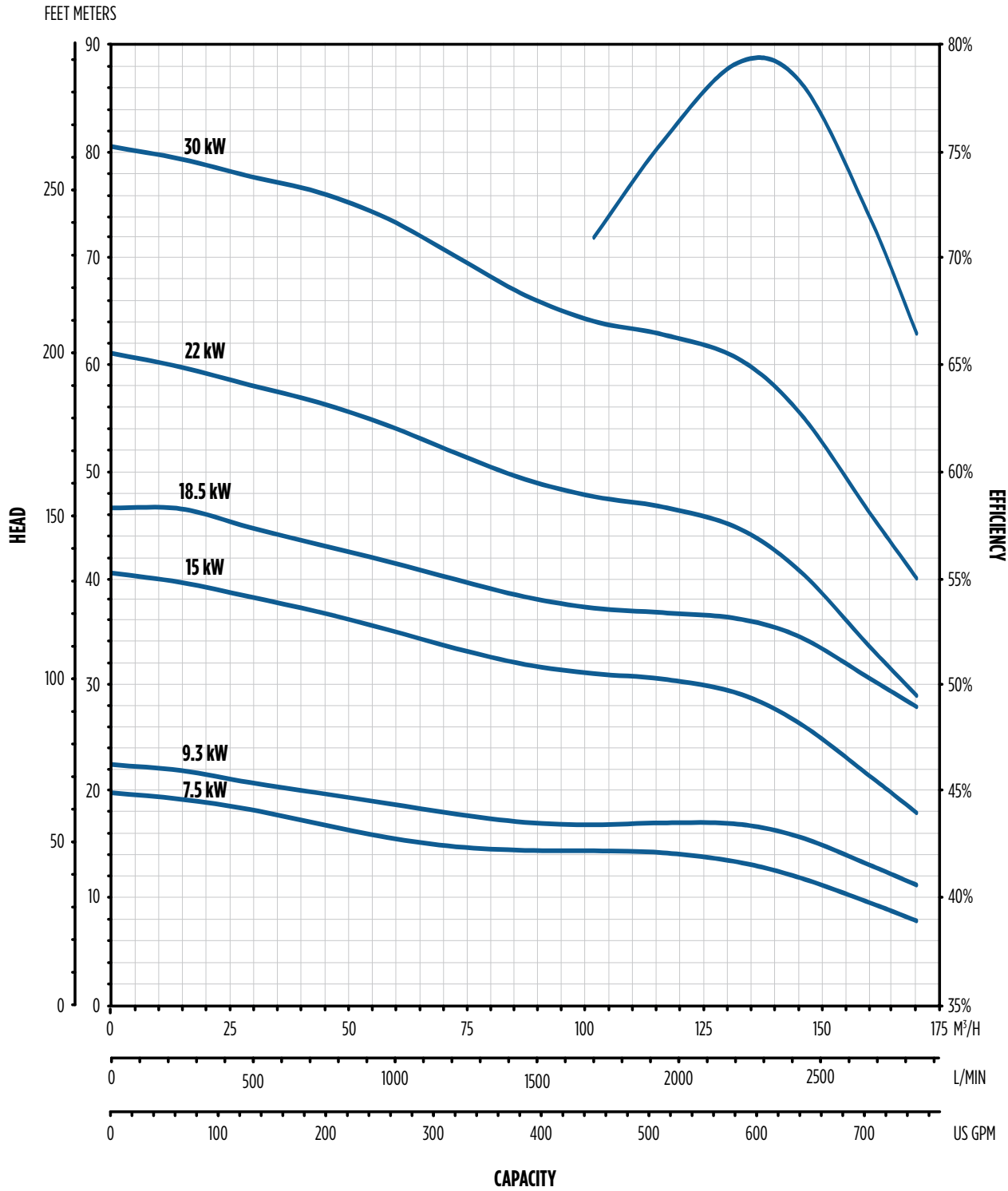

Note: Performance based on 68 °F / 20 °C fresh water, 6" motor at 2900 rpm

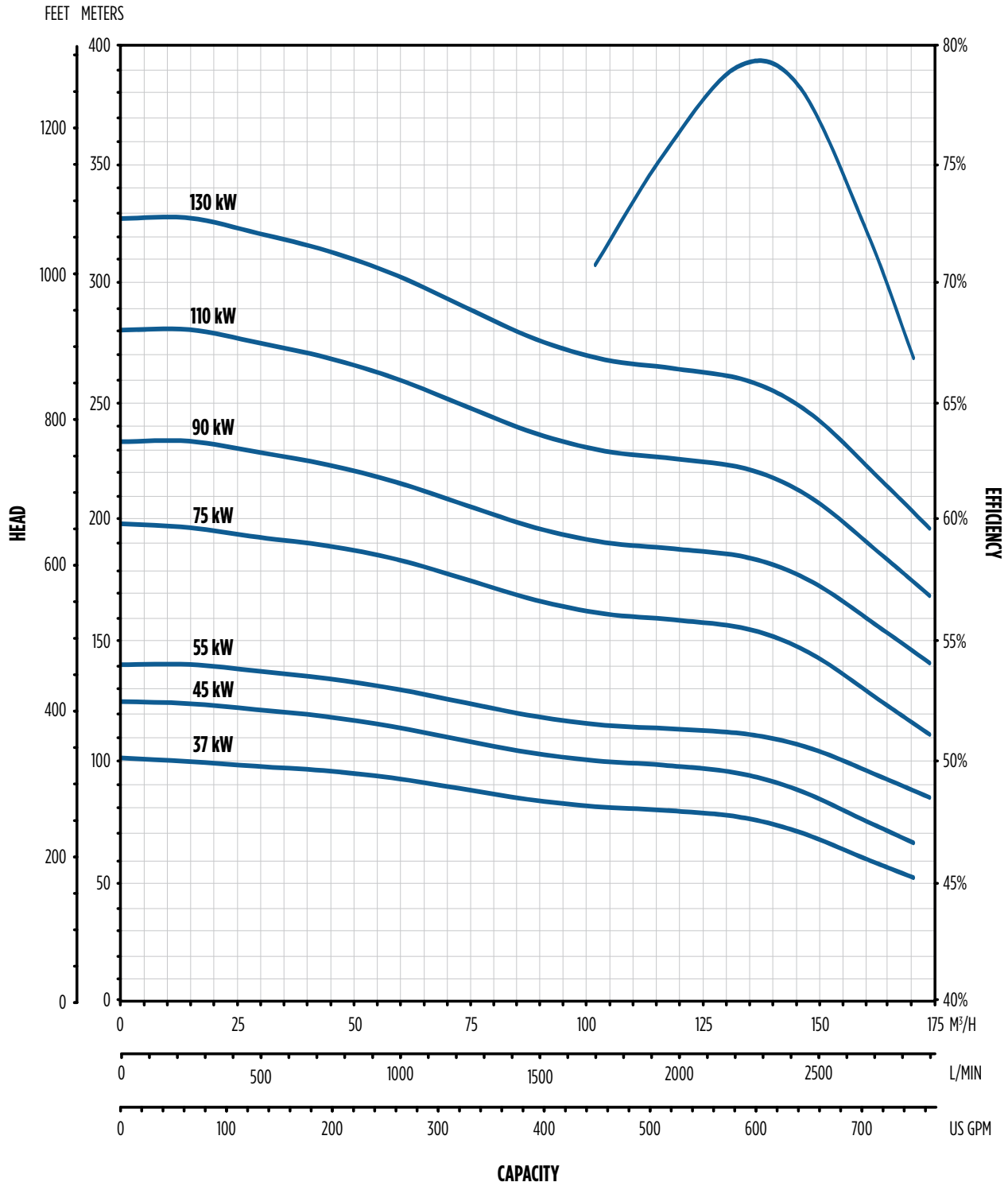

Note: Performance based on 68 °F / 20 °C fresh water, 6" motor at 2900 rpm

50 Hz 141STS SERIES Submersible Turbine Pumps

INFORMATION - 8" 141 M³/H

DIMENSIONS

kW	Stages	Trim	Motor	Dimensions [mm]			Motor Wt. [kg]	Pump Wt. [kg]
				P	M*	MD*		
7.5	1	1C	6"	645	645	138	46.7	43.1
9.3	1	1B	6"	645	678	138	49.3	43.1
15	2	1B, 1C	6"	825	777	138	57.2	57.2
18.5	2	2A	6"	825	841	138	63.5	57.2
22	3	2B, 1C	6"	1005	907	138	69.9	70.8
30	4	3B, 1C	6"	1185	1036	138	82.6	84.8
30	4	3B, 1C	8"	1220	925	196	124.3	95.3
37	5	4B, 1C	6"	1365	1405	138	119.3	98.4
37	5	1A, 2B, 2C	8"	1400	1001	196	140.2	109.3
45	6	3A, 1B, 2C	6"	1545	1557	138	132.0	112.5
45	6	1A, 3B, 2C	8"	1580	1069	196	156.0	123.4
55	6	6A	8"	1580	1204	196	181.0	123.4
75	9	3A, 6B	8"	2120	1394	196	218.2	164.7
93	10	10A	8"	2300	1748	196	291.9	178.7
110	12	12A	8"	2660	1976	196	340	206.7
130	14	14A	8"	3020	2179	196	375.2	234.7

*MD diameter = Franklin Electric Motor, M = Maximum Length of Franklin Electric Motor

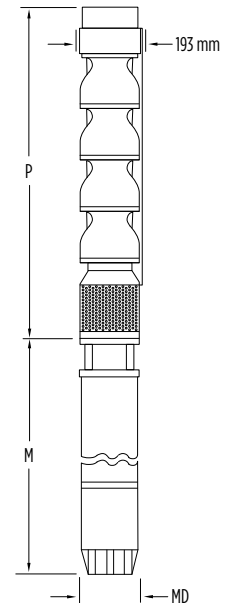

ORDERING

kW	Stages	Trim	Motor	Discharge	Order No.	Model No.	Ship Wt. [kg]
7.5	1	1C	6"	6" BSPP	97080141101	141STS7D8C5-0166	50.3
9.3	1	1B	6"	6" BSPP	97080141301	141STS9D8B5-0166	50.3
15	2	1B, 1C	6"	6" BSPP	97080141102	141STS15D8X5-0266	65.3
18.5	2	2A	6"	6" BSPP	97080141302	141STS18D8A5-0266	65.3
22	3	2B, 1C	6"	6" BSPP	97080141103	141STS22D8X5-0366	80.3
30	4	3B, 1C	6"	6" BSPP	97080141104	141STS30D8X5-0466	95.7
30	4	3B, 1C	8"	6" BSPP	97080141904	141STS30D8X5-0486	106.1
37	5	4B, 1C	6"	6" BSPP	97080141105	141STS37D8X5-0566	111.1
37	5	1A, 2B, 2C	8"	6" BSPP	97080141905	141STS37D8X5-0586	122
45	6	3A, 1B, 2C	6"	6" BSPP	97080141106	141STS45D8X5-0666	125.1
45	6	1A, 3B, 2C	8"	6" BSPP	97080141706	141STS45D8X5-0686	137.4
55	6	6A	8"	6" BSPP	97080141906	141STS55D8A5-0686	137.4
75	9	3A, 6B	8"	6" BSPP	97080141909	141STS75D8X5-0986	199.6
93	10	10A	8"	6" BSPP	97080141910	141STS90D8A5-1086	219.1
110	12	12A	8"	6" BSPP	97080141912	141STS110D8A5-1286	248
130	14	14A	8"	6" BSPP	97080141914	141STS130D8A5-1486	279

SPECIFICATIONS

Minimum Well I.D.	203 mm / 8"
Minimum Submergence Above Inlet	3 m / 10'
Discharge	4" or 6" BSPP

Note: Refer to Franklin Electric AIM data for motor cooling requirements.

MATERIALS

Part	Material	Specification No.
Discharge Bracket	Ductile Iron	ASTM A536 65-45-12
Top Bowl	Ductile Iron	ASTM A536 65-45-12
Intermediate Bowl	Ductile Iron	ASTM A536 65-45-12
Bearings, Disch. & Suction	Bronze	ASTM B584 C89835
Impeller	304 Stainless Steel	ASTM A743/A743M CF8
Pump Shaft	416 Stainless Steel	ASTM A582 S41600
Suction Bracket	Ductile Iron	ASTM A536 65-45-12
Bowl Bearing	Rubber	Rubber
Sand Collar	300 Stainless Steel	ASTM A666
Suction Screen	302 Stainless Steel	ASTM A240 S30200
Cable Guard	300 Stainless Steel	ASTM A666
Shaft Coupling	416 Stainless Steel	ASTM A582 S41600
Upthrust Bolt	300 Stainless Steel	ASTM A666
Taper Lock	416 Stainless Steel	ASTM A582 S41600
Bolting	300 Stainless Steel	ASTM A666

Note: Contact customer service for available bowl bearing and shaft options.

50 Hz 141STS SERIES Submersible Turbine Pumps

EXPLODED PARTS - 8" 141 M³/H

REPAIR PARTS

Item No.	Description	Part No.	Qty.
1, 2	Upthrust Bolt/Nut Kit	305471553	1
3	Discharge 4" BSPP (42-190)	305471979	1
	Discharge 6" BSPP (42-190)	305471980	
4	Top Bearing - Bronze (Included in 5)	305471990	As Req.
5	Top Bowl with Bronze Bearing	305471991	As Req.
	Top Bowl with Bronze Bearing XP	305471992	
6	Bowl Bolt Kit (8 pcs.)*	305471549	As Req.
	Bowl Bolt Kit (500 pcs.)	305471551	
7	8" Bowl Bearing - Rubber (Included in 8)	305471400	As Req.
	8" Bowl Bearing - Viton (Included in 8)	305471401	
	8" Bowl Bearing - Bronze (Included in 8)	305471379	
8	Bowl and Bearing Assembly - Bronze	305471528	As Req.
	Bowl and Bearing Assembly XP - Bronze	305471531	
	Bowl and Bearing Assembly - Rubber	305471527	
	Bowl and Bearing Assembly XP - Rubber	305471530	
	Bowl and Bearing Assembly - Viton	305471529	
9	Taper Lock Collet Kit (Included in 10)	305471371	As Req.
10	Sand Cap w/ Set Screws	305471373	1
11	Motor Bracket Bearing - Bronze (Included in 14)	305471379	1
12	6" Motor Bracket with Bronze Bearing	305471438	As Req.
	8" Motor Bracket with Bronze Bearing	305471435	
13	Suction Screen with Screws for 6" Motor Bracket	305471375	1
	Suction Screen with Screws for 8" Motor Bracket	305471376	
14	Cable Guard Screw Kit	305471000	1
15	8" x 6" Motor Coupling	305471403	1
	8" x 8" Motor Coupling	305471404	
Not Shown	6" Motor Bolt Kit	305352901	1
	8" Motor Bolt Kit	305352902	1
	Nameplate with Drive Screws	305418901	1
	Owner's Manual	106089101	1

* Pumps with 13 stages or more require double bolting. Two bolt kits per stage are required for the 13th stage and above.

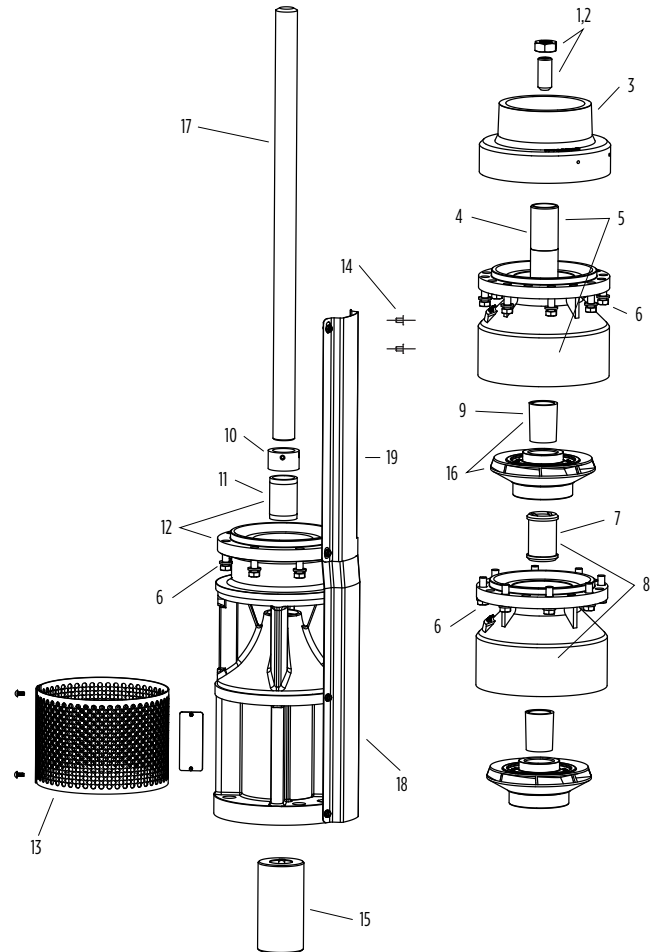

IMPELLER

Item No.	Description	Diameter [mm]	Angle	Kit w/ Collet
16	A Trim	144.07	17°	305471593
	B Trim	138.46		305471594
	C Trim	132.72		305471595

Note: Shaft and cable guard information located on the next page.

416 SS SHAFT*

Part No.	Length [mm]
305471367	1219
305471368	1829
305471369	2438
305471370	3048

*Double ended

SHAFT (8" X 6")*

Item No.	Stages	Length [mm]	Part No.	
			416 SS	Chrome
17	1	455	305472005	305472104
	2	595	305472007	305472106
	3	735	305472009	305472108
	4	875	305472011	305472110
	5	1015	305472013	305472112
	6	1155	305472015	305472114
	7	1295	305472017	305472116
	8	1435	305472019	305472118
	9	1575	305472021	305472120
	10	1715	305472023	305472122
	11	1855	305472025	305472124
	12	1995	305472027	305472126
	13	2135	305472029	305472128
	14	2275	305472031	305472130
	15	2415	305472033	305472132

* 8" pump with 6" motor bracket

SHAFT (8" X 8")*

Item No.	Stages	Length [mm]	Part No.	
			416 SS	Chrome
17	1	476	305472006	305472105
	2	608	305472008	305472107
	3	748	305472010	305472109
	4	888	305472012	305472111
	5	1028	305472014	305472113
	6	1168	305472016	305472115
	7	1308	305472018	305472117
	8	1448	305472020	305472119
	9	1588	305472022	305472121
	10	1728	305472024	305472123
	11	1868	305472026	305472125
	12	2008	305472028	305472127
	13	2148	305472030	305472129
	14	2288	305472032	305472131
	15	2428	305472034	305472133
	16	2568	305472035	305472134
	17	2708	305472036	305472135
	18	2848	305472037	305472136

* 8" pump with 8" motor bracket

CABLE GUARD (8" X 6" PRE-CUT)*

Item No.	Stages	Length [mm]	Part No.
18, 19	1	200	305471790
	2	340	305471793
	3	480	305471796
	4	621	305471799
	5	761	305471801
	6	901	305471804
	7	1041	305471806
	8	1181	305471838
	9	1321	305471853
	10	1461	305471839
	11	1601	305471872
	12	1741	305471843
	13	1881	305471874
	14	2021	305471876
	15	2161	305471844

* 8" pump with 6" motor bracket

CABLE GUARD (8" X 8" PRE-CUT)*

Item No.	Stages	Length [mm]	Part No.
19	1	568	305471864
	2	708	305471868
	3	848	305471870
	4	988	305471830
	5	1128	305471832
	6	1268	305471835
	7	1408	305471837
	8	1548	305471808
	9	1688	305471810
	10	1828	305471812
	11	1968	305471815
	12	2108	305471817
	13	2248	305471877
	14	2388	305471841
	15	2528	305471842
	16	2668	305471840
	17	2808	305471878
	18	2948	305471824

* 8" pump with 8" motor bracket

CABLE GUARD (BULK)

Item No.	Description	Length [mm]	Part No.
18, 19	Cable Guard 6" Motor Bracket Section*	359	305471001
	Cable Guard (10' Section)	3048	305471789

* Required for 6" motor bracket

ASEAN

Franklin Electric (SEA) Pte. Ltd.
17 Changi Business Park Central 1
06-05, Honeywell Building
Singapore 486 073

Phone: +65.6789.6865
Fax: +65.6789.0155

INDIA

Franklin Electric India Pvt. Ltd.
21, Alindra , GIDC - Manjusar,
Post Lamdapura , Savli - 391 775,
Dist Vadodara – 390010 (GUJARAT)

Phone: +02667-268600/01

AUSTRALIA / NEW ZEALAND

Franklin Electric (Australia) Pty. Ltd.
106 - 110 Micro Circuit
Dandenong South, Victoria 3175
Australia

Phone: +61.3.9799.5000
Fax: +61.3.9799.5050
Hotline: 1.300 FRANKLIN (1.300.372.655)

LATIN AMERICA

Motores Franklin S.A. de C.V.
Avenida Churubusco #1600 (Bodega #16)
Col. Francisco I. Madero
Monterrey, N.L.
Mexico C.P. 64560

Phone: +52.81.8000.1000
Fax: +52.818.864.8445

CHINA

Franklin Electric (Shanghai) Co. Ltd.
Unit 1002-03, Shanghai Central Plaza
No. 227, Huang Pi Bei Road
Shanghai 200003, China

Phone: +86.21.6327.0909
Fax: +86.21.6327.0910

KOREA

Franklin Electric B.V. Korea
Room 502 (BangBaeDong, BangBae The O Superium#1)
3-4 SeoCho-Daero
SeoCho-Gu, Seoul 137-974
Republic of Korea

Phone: +82.2.3473.3353
Fax: +82.2.3473.3352

JAPAN

Franklin Electric International, Inc.
Aoba Bldg. 4F
1-14-7, Sugamo
Toshima-Ku, Tokyo 170-0002, Japan

Phone: +81.3.5319.1251
Fax: +81.3.5319.1252

UNITED STATES

Franklin Electric Co., Inc.
9255 Coverdale Road
Fort Wayne, Indiana 46809 USA

Phone: +1.260.824.2900
Fax: +1.260.824.2909

