



# **FPS**4400

## 50Hz





# **Table of Contents**

## **4” Submersible Pumps**

|                                       |           |
|---------------------------------------|-----------|
| <b>4400 Tri-Seal Pumps .....</b>      | <b>2</b>  |
| 18 LPM Tri-Seal .....                 | 4         |
| 25 LPM Tri-Seal .....                 | 6         |
| 30 LPM Tri-Seal .....                 | 8         |
| 45 LPM Tri-Seal .....                 | 10        |
| 60 LPM Tri-Seal .....                 | 12        |
| 70 LPM Tri-Seal .....                 | 14        |
| <br>                                  |           |
| <b>4400 High Capacity Pumps .....</b> | <b>16</b> |
| 100 LPM High Capacity .....           | 18        |
| 150 LPM High Capacity .....           | 20        |
| 200 LPM High Capacity .....           | 22        |
| 270 LPM High Capacity .....           | 24        |



## 4400 Tri-Seal

The standard FPS 4400 4" submersible pump features the new Tri-Seal floating stage system. This new stage system further improves efficiency and protects against wear when pumping abrasives like sand.



### Features:

- 300 series stainless steel hub floats with the impeller maintaining a positive seal.
- Phenolic washer provides downthrust protection.
- Celcon<sup>®</sup> impeller provides high efficiency performance and abrasion resistance.
- Noryl<sup>®</sup> diffuser and disc - proven abrasion resistant material.
- Floating stage design allows impeller to float independently.
- Removable, spring-loaded check valve.
- Maximum water temperature: 120 °F / 49 °C.
- Ceramic shaft sleeve and rubber discharge bearing protect shaft and eliminate sand wear.
- Powered by Franklin Electric corrosion resistant 4" submersible motors.

Celcon<sup>®</sup> is a Registered Trademark of the Celanese Corporation.

Noryl<sup>®</sup> is a Registered Trademark of G.E.

Patented impeller hub seal system seals radially and axially to prevent fluid recirculation, providing high performance in the harshest conditions.

ICSA CERTIFIED  
PUMP END ONLY



Drinking Water  
NSF/ANSI 61

## Tri-Seal™ Floating Stage System

U.S. Patent No. 7,290,984

### Seal 1

Phenolic washer provides axial sealing as impeller floats in the stage.



### Seal 2

Stainless steel hub seal is captured but not stationary, floating with the impeller for maximum sealing.

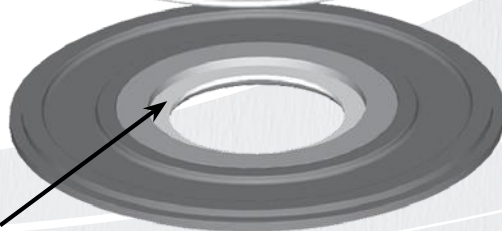
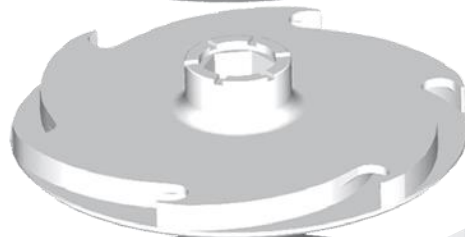
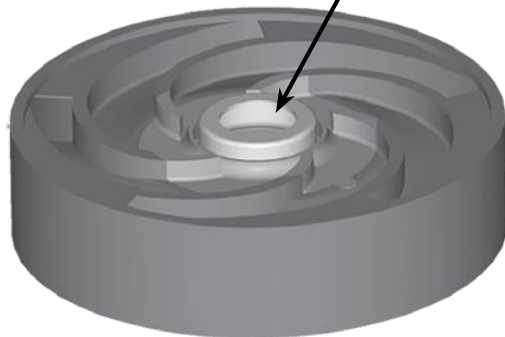

### Seal 3

Stainless steel impeller eye seal.

# FPS 4400

## 18 LPM Tri-Seal

### 18 LPM Tri-Seal Ordering Information

#### Plastic

| LPM | HP  | kW   | Stages | Model Description | Order No. |
|-----|-----|------|--------|-------------------|-----------|
| 18  | 1/2 | 0.37 | 9      | 18FA05P4-PEXB     | 95690506  |
|     | 3/4 | 0.55 | 13     | 18FA07P4-PEXB     | 95690511  |
|     | 1   | 0.75 | 17     | 18FA1P4-PEXB      | 95690516  |
|     | 1.5 | 1.1  | 26     | 18FA15P4-PEXB     | 95690521  |

#### Stainless Steel

| LPM | HP  | kW   | Stages | Model Description | Order No. |
|-----|-----|------|--------|-------------------|-----------|
| 18  | 1/2 | 0.37 | 9      | 18FA05S4-PEXB     | 95710506  |
|     | 3/4 | 0.55 | 13     | 18FA07S4-PEXB     | 95710511  |
|     | 1   | 0.75 | 17     | 18FA1S4-PEXB      | 95710516  |
|     | 1.5 | 1.1  | 26     | 18FA15S4-PEXB     | 95710521  |
|     | 2   | 1.5  | 35     | 18FA2S4-PEXB      | 95710526  |

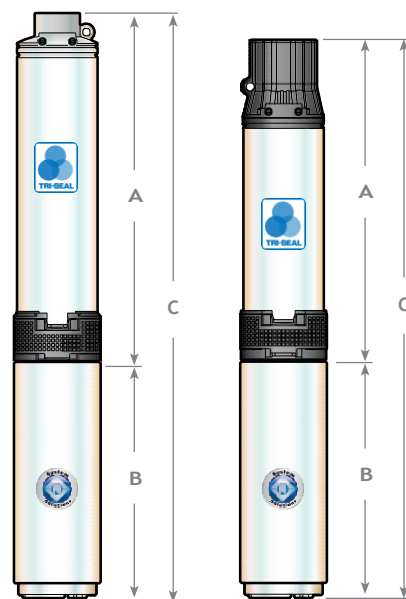

### 18 LPM Tri-Seal Dimensional Data

#### Plastic

| LPM | HP  | kW   | 3-Phase |        |        | 3-Wire |        |        | P.E. Weight (kg) |
|-----|-----|------|---------|--------|--------|--------|--------|--------|------------------|
|     |     |      | A (mm)  | B (mm) | C (mm) | A (mm) | B (mm) | C (mm) |                  |
| 18  | 1/2 | 0.37 | 370     | 242    | 611    | 370    | 242    | 611    | 3                |
|     | 3/4 | 0.55 | 453     | 270    | 724    | 453    | 270    | 724    | 4                |
|     | 1   | 0.75 | 535     | 298    | 833    | 535    | 298    | 833    | 5                |
|     | 1.5 | 1.1  | 775     | 298    | 1073   | 775    | 345    | 1120   | 6                |

#### Stainless Steel

| LPM | HP  | kW   | 3-Phase |        |        | 3-Wire |        |        | P.E. Weight (kg) |
|-----|-----|------|---------|--------|--------|--------|--------|--------|------------------|
|     |     |      | A (mm)  | B (mm) | C (mm) | A (mm) | B (mm) | C (mm) |                  |
| 18  | 1/2 | 0.37 | 366     | 242    | 607    | 366    | 242    | 607    | 4                |
|     | 3/4 | 0.55 | 449     | 270    | 719    | 449    | 270    | 719    | 5                |
|     | 1   | 0.75 | 533     | 298    | 831    | 533    | 298    | 831    | 6                |
|     | 1.5 | 1.1  | 774     | 298    | 1072   | 774    | 345    | 1119   | 7                |
|     | 2   | 1.5  | 961     | 345    | 1307   | 961    | 384    | 1345   | 8                |

Note: P.E. – Pump end only

Product dimensions assume the FPS pump end is assembled to a 4" Franklin Electric submersible motor.

Maximum diameter with cable guard is 99.1 mm

# 50 Hz Tri-Seal



## 18 LPM Tri-Seal Performance Curves

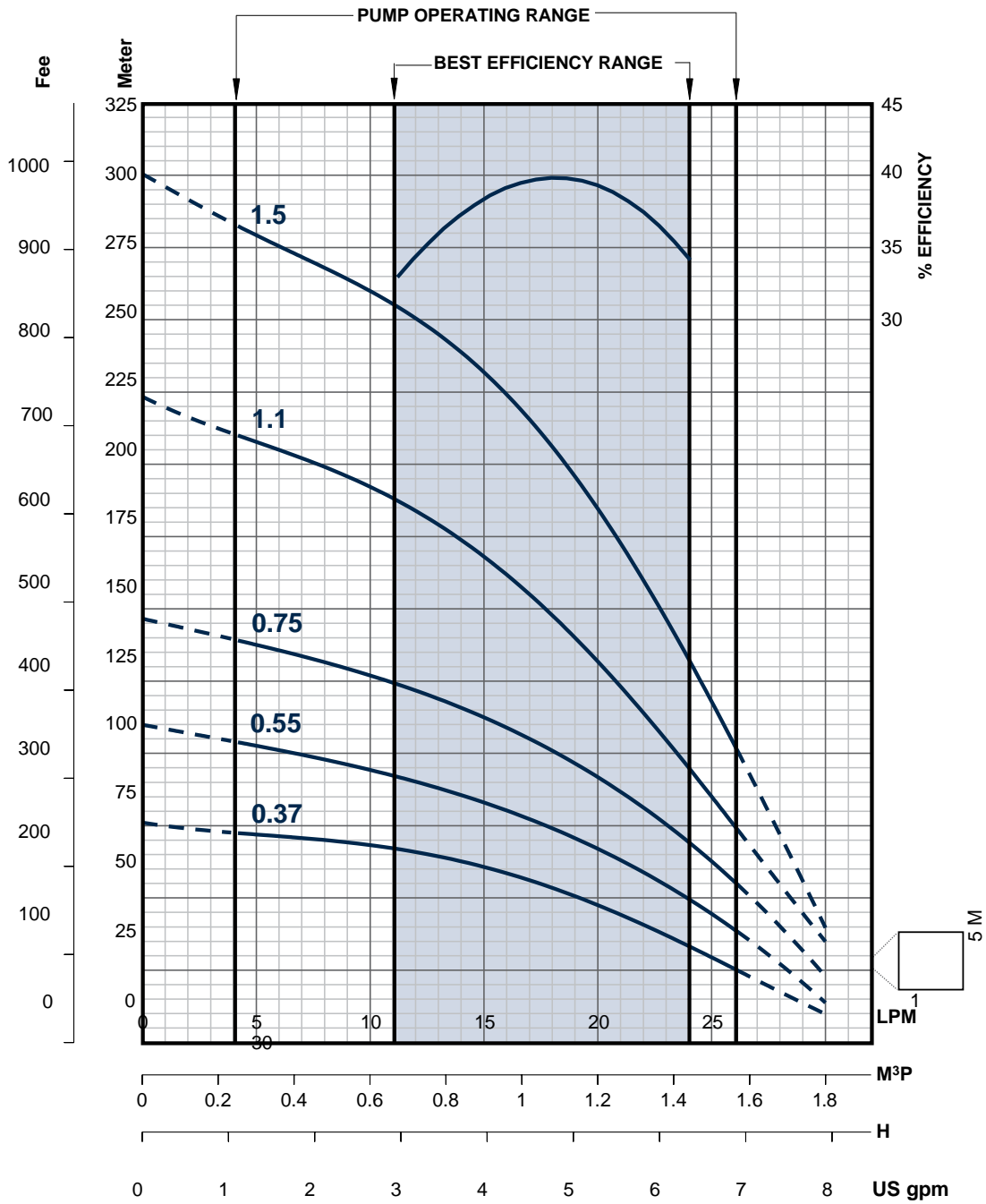

25 LPM Tri-Seal

25 LPM Tri-Seal Ordering Information

Plastic

| LPM | HP  | kW   | Stages | Model Description | Order No. |
|-----|-----|------|--------|-------------------|-----------|
| 25  | 1/2 | 0.37 | 8      | 25FA05P4-PEXB     | 95690706  |
|     | 3/4 | 0.55 | 12     | 25FA07P4-PEXB     | 95690711  |
|     | 1   | 0.75 | 16     | 25FA1P4-PEXB      | 95690716  |
|     | 1.5 | 1.1  | 24     | 25FA15P4-PEXB     | 95690721  |

Stainless Steel

| LPM | HP  | kW   | Stages | Model Description | Order No. |
|-----|-----|------|--------|-------------------|-----------|
| 25  | 1/2 | 0.37 | 8      | 25FA05S4-PEXB     | 95710706  |
|     | 3/4 | 0.55 | 12     | 25FA07S4-PEXB     | 95710711  |
|     | 1   | 0.75 | 16     | 25FA1S4-PEXB      | 95710716  |
|     | 1.5 | 1.1  | 24     | 25FA15S4-PEXB     | 95710721  |
|     | 2   | 1.5  | 32     | 25FA2S4-PEXB      | 95710726  |

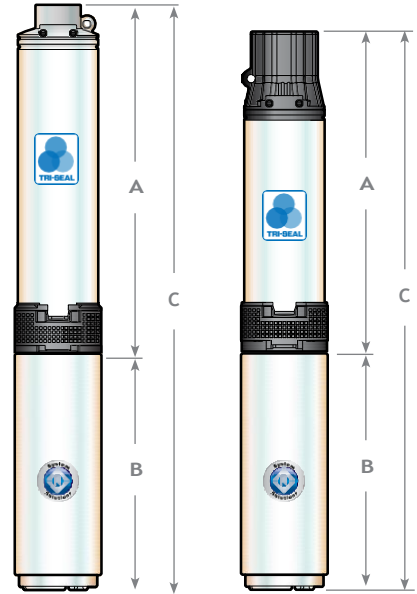

25 LPM Tri-Seal Dimensional Data

Plastic

| LPM | HP  | kW   | 3-Phase |        |        | 3-Wire |        |        | P.E. Weight (kg) |
|-----|-----|------|---------|--------|--------|--------|--------|--------|------------------|
|     |     |      | A (mm)  | B (mm) | C (mm) | A (mm) | B (mm) | C (mm) |                  |
| 25  | 1/2 | 0.37 | 349     | 242    | 591    | 349    | 242    | 591    | 2                |
|     | 3/4 | 0.55 | 431     | 270    | 702    | 431    | 270    | 702    | 3                |
|     | 1   | 0.75 | 514     | 298    | 812    | 514    | 298    | 812    | 5                |
|     | 1.5 | 1.1  | 680     | 298    | 978    | 680    | 345    | 1026   | 6                |

Stainless Steel

| LPM | HP  | kW   | 3-Phase |        |        | 3-Wire |        |        | P.E. Weight (kg) |
|-----|-----|------|---------|--------|--------|--------|--------|--------|------------------|
|     |     |      | A (mm)  | B (mm) | C (mm) | A (mm) | B (mm) | C (mm) |                  |
| 25  | 1/2 | 0.37 | 345     | 242    | 586    | 345    | 242    | 586    | 3                |
|     | 3/4 | 0.55 | 428     | 270    | 699    | 428    | 270    | 699    | 5                |
|     | 1   | 0.75 | 512     | 298    | 810    | 512    | 298    | 810    | 6                |
|     | 1.5 | 1.1  | 679     | 298    | 977    | 679    | 345    | 1024   | 7                |
|     | 2   | 1.5  | 899     | 345    | 1244   | 899    | 384    | 1282   | 9                |

Note: P.E. – Pump end only

Product dimensions assume the FPS pump end is assembled to a 4" Franklin Electric submersible motor.

Maximum diameter with cable guard is 99.1 mm



# 50 Hz Tri-Seal

4" Submersible Pumps



## 25 LPM Tri-Seal Performance Curves

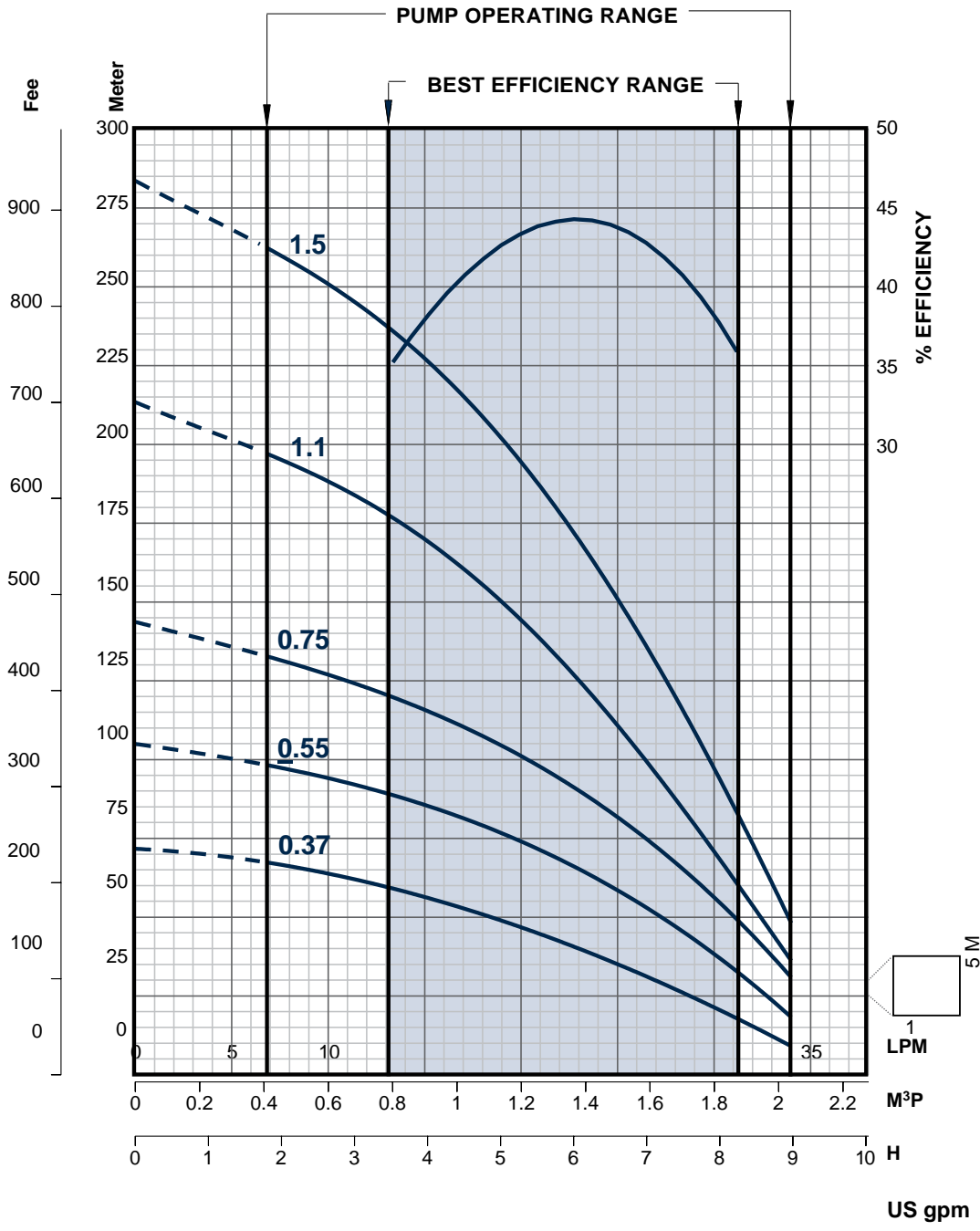

30 LPM Tri-Seal

30 LPM Tri-Seal Ordering Information

Plastic

| LPM | HP  | kW   | Stages | Model Description | Order No. |
|-----|-----|------|--------|-------------------|-----------|
| 30  | 1/2 | 0.37 | 6      | 30FA05P4-PEXB     | 95691006  |
|     | 3/4 | 0.55 | 8      | 30FA07P4-PEXB     | 95691011  |
|     | 1   | 0.75 | 12     | 30FA1P4-PEXB      | 95691016  |
|     | 1.5 | 1.1  | 18     | 30FA15P4-PEXB     | 95691021  |

Stainless Steel

| LPM | HP  | kW   | Stages | Model Description | Order No. |
|-----|-----|------|--------|-------------------|-----------|
| 30  | 1/2 | 0.37 | 6      | 30FA05S4-PEXB     | 95711006  |
|     | 3/4 | 0.55 | 8      | 30FA07S4-PEXB     | 95711011  |
|     | 1   | 0.75 | 12     | 30FA1S4-PEXB      | 95711016  |
|     | 1.5 | 1.1  | 18     | 30FA15S4-PEXB     | 95711021  |
|     | 2   | 1.5  | 24     | 30FA2S4-PEXB      | 95711026  |
|     | 3   | 2.2  | 37     | 30FA3S4-PEXB      | 95711031  |
|     | 5   | 3.7  | 59     | 30FA5S4-PEXB      | 95711036  |
|     | 7.5 | 5.5  | 78     | 30FA7S4-PEXB      | 95711041  |

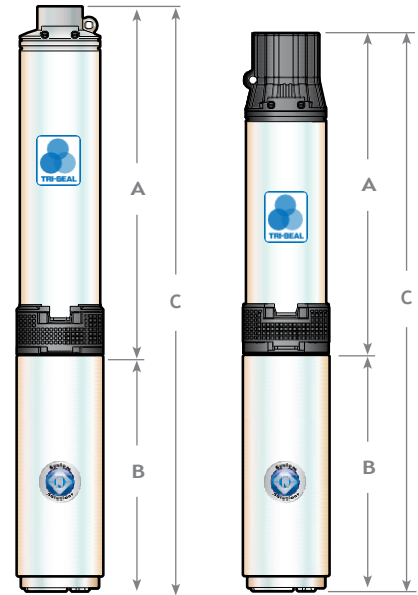

30 LPM Tri-Seal Dimensional Data

Plastic

| LPM | HP  | kW   | 3-Phase |        |        | 3-Wire |        |        | P.E. Weight (kg) |
|-----|-----|------|---------|--------|--------|--------|--------|--------|------------------|
|     |     |      | A (mm)  | B (mm) | C (mm) | A (mm) | B (mm) | C (mm) |                  |
| 30  | 1/2 | 0.37 | 320     | 242    | 561    | 320    | 242    | 561    | 2                |
|     | 3/4 | 0.55 | 364     | 270    | 634    | 364    | 270    | 634    | 3                |
|     | 1   | 0.75 | 465     | 298    | 763    | 465    | 298    | 763    | 3                |
|     | 1.5 | 1.1  | 647     | 298    | 945    | 647    | 345    | 992    | 5                |

Stainless Steel

| LPM | HP  | kW   | 3-Phase |        |        | 3-Wire |        |        | P.E. Weight (kg) |
|-----|-----|------|---------|--------|--------|--------|--------|--------|------------------|
|     |     |      | A (mm)  | B (mm) | C (mm) | A (mm) | B (mm) | C (mm) |                  |
| 30  | 1/2 | 0.37 | 315     | 242    | 556    | 315    | 242    | 556    | 4                |
|     | 3/4 | 0.55 | 359     | 270    | 629    | 359    | 270    | 629    | 4                |
|     | 1   | 0.75 | 453     | 298    | 751    | 453    | 298    | 751    | 5                |
|     | 1.5 | 1.1  | 642     | 298    | 940    | 642    | 345    | 987    | 7                |
|     | 2   | 1.5  | 780     | 345    | 1125   | 780    | 384    | 1163   | 8                |
|     | 3   | 2.2  | 1076    | 407    | 1484   | 1076   | 484    | 1560   | 9                |
|     | 5   | 3.7  | 1676    | 589    | 2265   | 1676   | 741    | 2417   | 15               |
|     | 7.5 | 5.5  | 2166    | 741    | 2907   | N/A    | N/A    | N/A    | 19               |

Note: P.E. – Pump end only  
 Product dimensions assume the FPS pump end is assembled to a 4" Franklin Electric submersible motor.  
 Maximum diameter with cable guard is 99.1 mm

# 50 Hz Tri-Seal



## 30 LPM Tri-Seal Performance Curves

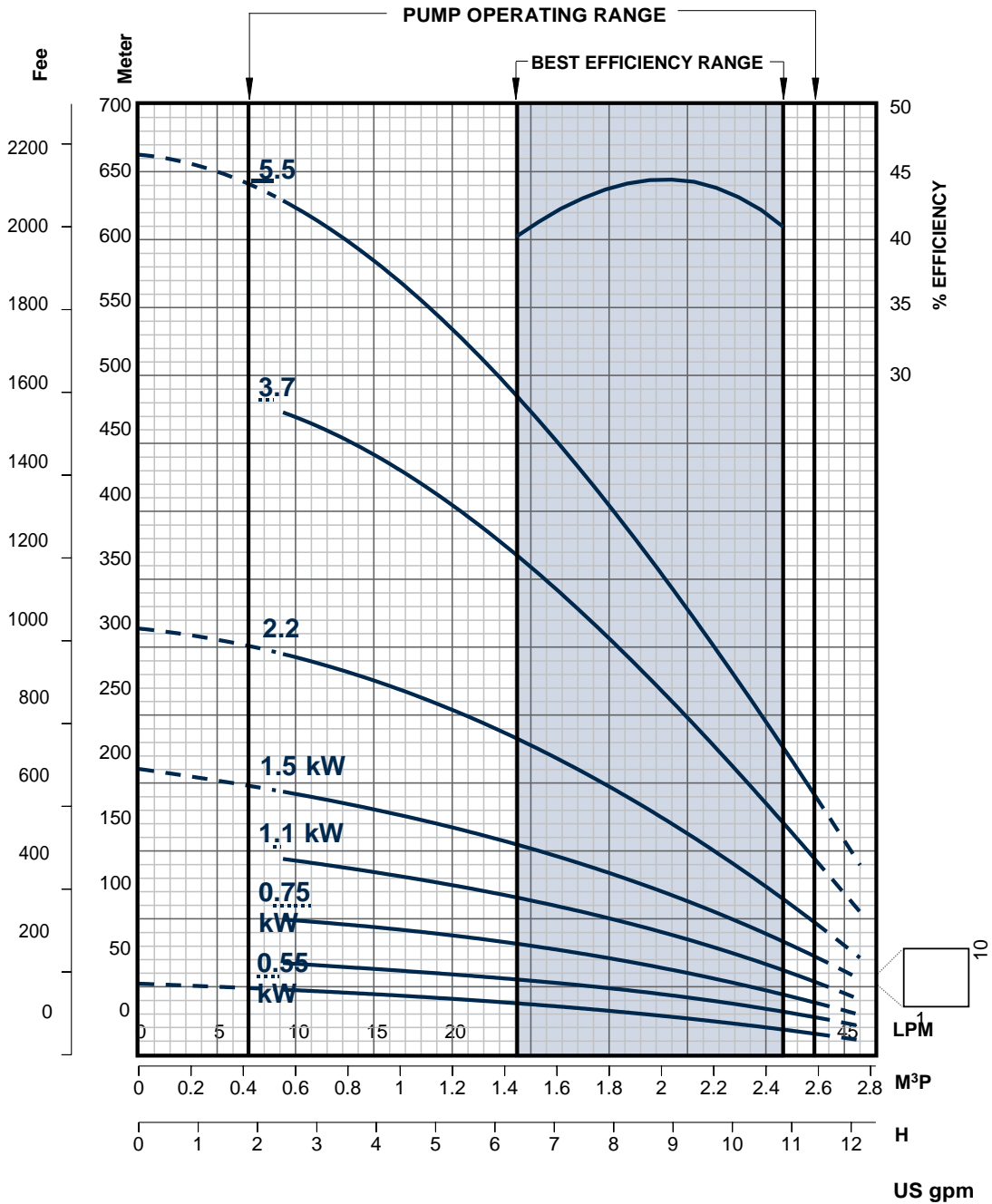

45 LPM Tri-Seal

45 LPM Tri-Seal Ordering Information

Plastic

| LPM | HP  | kW   | Stages | Model Description | Order No. |
|-----|-----|------|--------|-------------------|-----------|
| 45  | 1/2 | 0.37 | 4      | 45FA05P4-PEXB     | 95691506  |
|     | 3/4 | 0.55 | 8      | 45FA07P4-PEXB     | 95691511  |
|     | 1   | 0.75 | 10     | 45FA1P4-PEXB      | 95691516  |
|     | 1.5 | 1.1  | 15     | 45FA15P4-PEXB     | 95691521  |

Stainless Steel

| LPM | HP  | kW   | Stages | Model Description | Order No. |
|-----|-----|------|--------|-------------------|-----------|
| 45  | 1/2 | 0.37 | 4      | 45FA05S4-PEXB     | 95711506  |
|     | 3/4 | 0.55 | 8      | 45FA07S4-PEXB     | 95711511  |
|     | 1   | 0.75 | 10     | 45FA1S4-PEXB      | 95711516  |
|     | 1.5 | 1.1  | 15     | 45FA15S4-PEXB     | 95711521  |
|     | 2   | 1.5  | 19     | 45FA2S4-PEXB      | 95711526  |
|     | 3   | 2.2  | 31     | 45FA3S4-PEXB      | 95711531  |
|     | 5   | 3.7  | 46     | 45FA5S4-PEXB      | 95711536  |
|     | 7.5 | 5.5  | 62     | 45FA7S4-PEXB      | 95711541  |

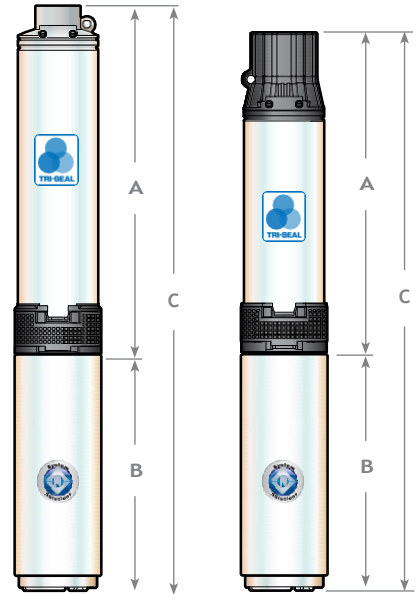

45 LPM Tri-Seal Dimensional Data

Plastic

| LPM | HP  | kW   | 3-Phase |        |        | 3-Wire |        |        | P.E. Weight (kg) |
|-----|-----|------|---------|--------|--------|--------|--------|--------|------------------|
|     |     |      | A (mm)  | B (mm) | C (mm) | A (mm) | B (mm) | C (mm) |                  |
| 45  | 1/2 | 0.37 | 279     | 242    | 520    | 281    | 241    | 522    | 2                |
|     | 3/4 | 0.55 | 363     | 270    | 633    | 363    | 270    | 633    | 3                |
|     | 1   | 0.75 | 410     | 298    | 708    | 410    | 298    | 708    | 3                |
|     | 1.5 | 1.1  | 525     | 298    | 823    | 525    | 345    | 871    | 5                |

Stainless Steel

| LPM | HP  | kW   | 3-Phase |        |        | 3-Wire |        |        | P.E. Weight (kg) |
|-----|-----|------|---------|--------|--------|--------|--------|--------|------------------|
|     |     |      | A (mm)  | B (mm) | C (mm) | A (mm) | B (mm) | C (mm) |                  |
| 45  | 1/2 | 0.37 | 269     | 242    | 510    | 269    | 242    | 510    | 3                |
|     | 3/4 | 0.55 | 361     | 270    | 631    | 361    | 270    | 631    | 4                |
|     | 1   | 0.75 | 407     | 298    | 705    | 407    | 298    | 705    | 4                |
|     | 1.5 | 1.1  | 521     | 298    | 819    | 521    | 345    | 867    | 6                |
|     | 2   | 1.5  | 665     | 345    | 1010   | 665    | 384    | 1048   | 7                |
|     | 3   | 2.2  | 940     | 407    | 1347   | 940    | 484    | 1423   | 9                |
|     | 5   | 3.7  | 1379    | 589    | 1968   | 1379   | 741    | 2120   | 14               |
|     | 7.5 | 5.5  | 1745    | 741    | 2486   | N/A    | N/A    | N/A    | 18               |

Note: P.E. – Pump end only  
 Product dimensions assume the FPS pump end is assembled to a 4" Franklin Electric submersible motor.  
 Maximum diameter with cable guard is 99.1 mm

# 50 Hz Tri-Seal



## 45 LPM Tri-Seal Performance Curves

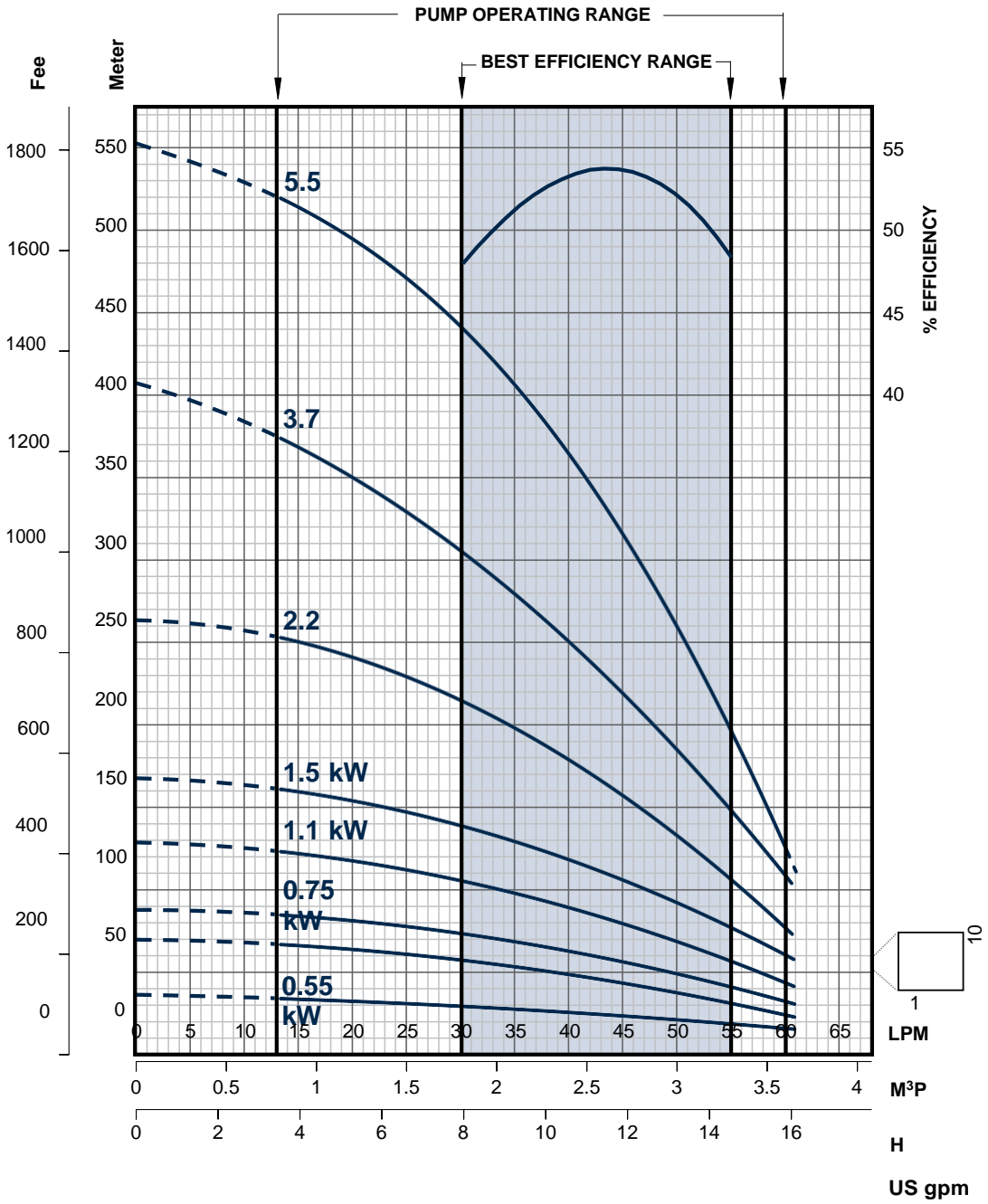

## 60 LPM Tri-Seal

### 60 LPM Tri-Seal Ordering Information

#### Plastic

| LPM | HP  | kW   | Stages | Model Description | Order No. |
|-----|-----|------|--------|-------------------|-----------|
| 60  | 3/4 | 0.55 | 6      | 60FA07P4-PEXB     | 95692006  |
|     | 1   | 0.75 | 8      | 60FA1P4-PEXB      | 95692011  |
|     | 1.5 | 1.1  | 11     | 60FA15P4-PEXB     | 95692016  |

#### Stainless Steel

| LPM | HP  | kW   | Stages | Model Description | Order No. |
|-----|-----|------|--------|-------------------|-----------|
| 60  | 3/4 | 0.55 | 6      | 60FA07S4-PEXB     | 95712006  |
|     | 1   | 0.75 | 8      | 60FA1S4-PEXB      | 95712011  |
|     | 1.5 | 1.1  | 11     | 60FA15S4-PEXB     | 95712016  |
|     | 2   | 1.5  | 16     | 60FA2S4-PEXB      | 95712021  |
|     | 3   | 2.2  | 26     | 60FA3S4-PEXB      | 95712026  |
|     | 5   | 3.7  | 39     | 60FA5S4-PEXB      | 95712036  |
|     | 7.5 | 5.5  | 52     | 60FA7S4-PEXB      | 95712041  |

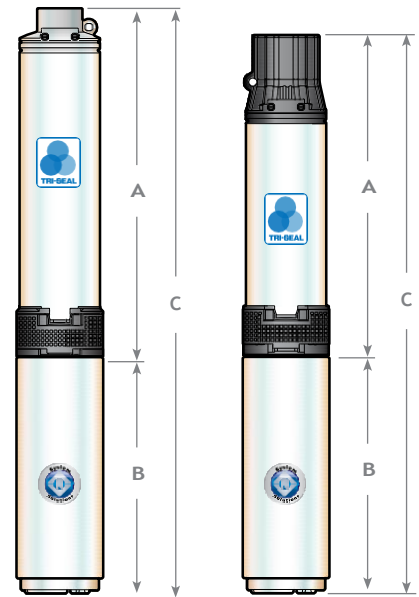

### 60 LPM Tri-Seal Dimensional Data

#### Plastic

| LPM | HP  | kW   | 3-Phase |        |        | 3-Wire |        |        | P.E. Weight (kg) |
|-----|-----|------|---------|--------|--------|--------|--------|--------|------------------|
|     |     |      | A (mm)  | B (mm) | C (mm) | A (mm) | B (mm) | C (mm) |                  |
| 60  | 3/4 | 0.55 | 368     | 270    | 639    | 368    | 270    | 639    | 3                |
|     | 1   | 0.75 | 430     | 298    | 728    | 430    | 298    | 728    | 4                |
|     | 1.5 | 1.1  | 524     | 298    | 822    | 524    | 345    | 870    | 4                |

#### Stainless Steel

| LPM | HP  | kW   | 3-Phase |        |        | 3-Wire |        |        | P.E. Weight (kg) |
|-----|-----|------|---------|--------|--------|--------|--------|--------|------------------|
|     |     |      | A (mm)  | B (mm) | C (mm) | A (mm) | B (mm) | C (mm) |                  |
| 60  | 3/4 | 0.55 | 364     | 270    | 634    | 364    | 270    | 634    | 4                |
|     | 1   | 0.75 | 426     | 298    | 724    | 426    | 298    | 724    | 4                |
|     | 1.5 | 1.1  | 520     | 298    | 818    | 520    | 345    | 865    | 6                |
|     | 2   | 1.5  | 674     | 345    | 1020   | 674    | 384    | 1058   | 6                |
|     | 3   | 2.2  | 1038    | 407    | 1445   | 1038   | 484    | 1522   | 8                |
|     | 5   | 3.7  | 1544    | 589    | 2133   | 1544   | 741    | 2285   | 13               |
|     | 7.5 | 5.5  | 1948    | 741    | 2689   | N/A    | N/A    | N/A    | 16               |

Note: P.E. – Pump end only

Product dimensions assume the FPS pump end is assembled to a 4" Franklin Electric submersible motor.

Maximum diameter with cable guard is 99.1 mm

# 50 Hz Tri-Seal

4" Submersible Pumps



## 60 LPM Tri-Seal Performance Curves

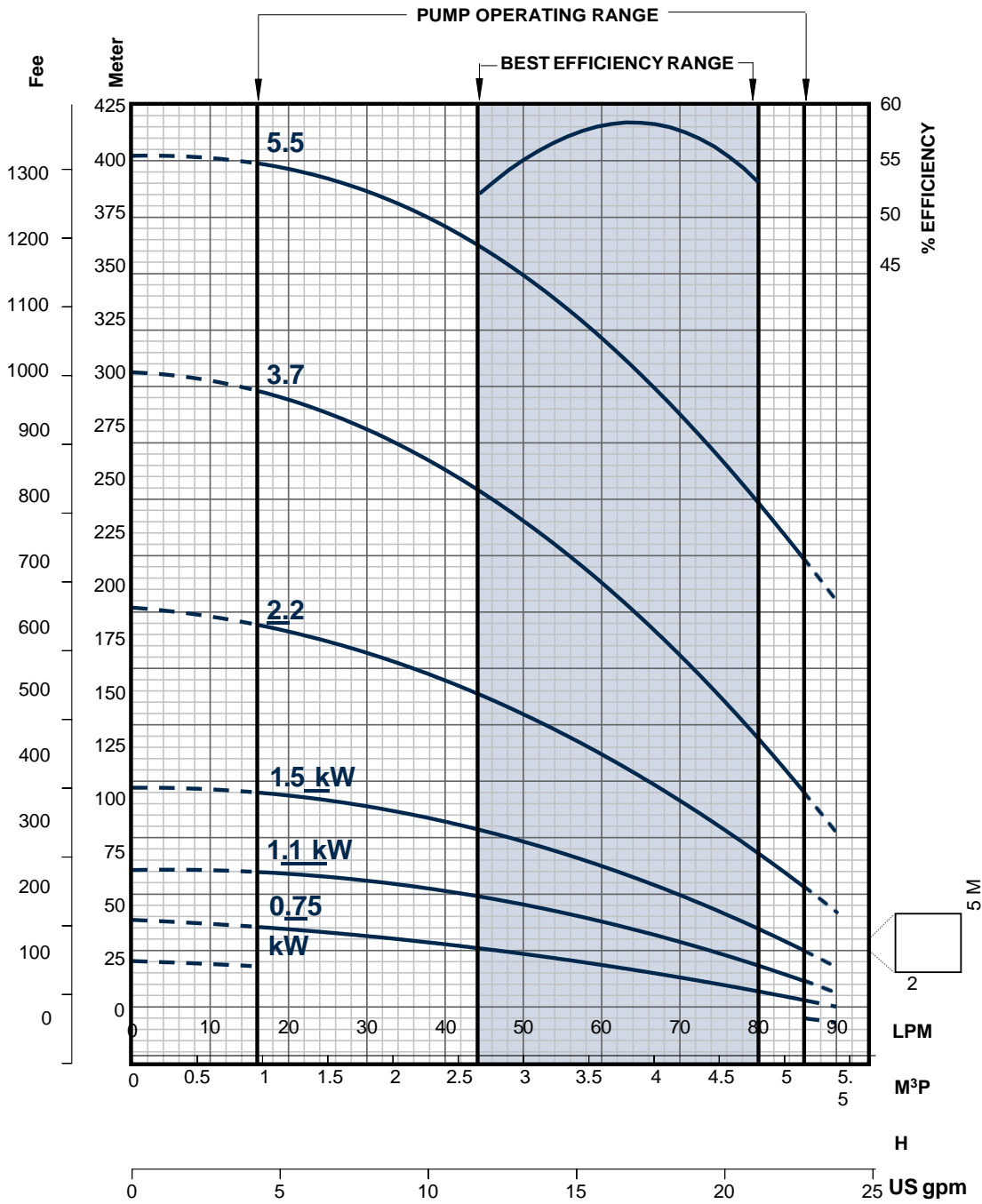

70 LPM Tri-Seal

70 LPM Tri-Seal Ordering Information

Plastic

| LPM | HP  | kW   | Stages | Model Description | Order No. |
|-----|-----|------|--------|-------------------|-----------|
| 70  | 1   | 0.75 | 7      | 70FA1P4-PEXB      | 95692506  |
|     | 1.5 | 1.1  | 10     | 70FA15P4-PEXB     | 95692511  |

Stainless Steel

| LPM | HP  | kW   | Stages | Model Description | Order No. |
|-----|-----|------|--------|-------------------|-----------|
| 70  | 1   | 0.75 | 7      | 70FA1S4-PEXB      | 95712506  |
|     | 1.5 | 1.1  | 10     | 70FA15S4-PEXB     | 95712511  |
|     | 2   | 1.5  | 14     | 70FA2S4-PEXB      | 95712516  |
|     | 3   | 2.2  | 22     | 70FA3S4-PEXB      | 95712521  |
|     | 5   | 3.7  | 35     | 70FA5S4-PEXB      | 95712536  |
|     | 7.5 | 5.5  | 44     | 70FA7S4-PEXB      | 95712541  |

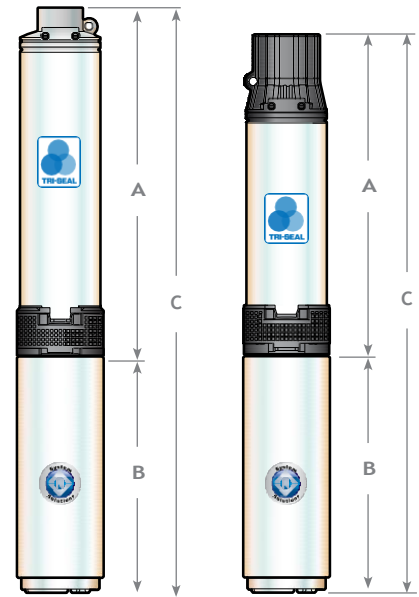

70 LPM Tri-Seal Dimensional Data

Plastic

| LPM | HP  | kW   | 3-Phase |        |        | 3-Wire |        |        | P.E. Weight (kg) |
|-----|-----|------|---------|--------|--------|--------|--------|--------|------------------|
|     |     |      | A (mm)  | B (mm) | C (mm) | A (mm) | B (mm) | C (mm) |                  |
| 70  | 1   | 0.75 | 399     | 298    | 697    | 399    | 298    | 697    | 4                |
|     | 1.5 | 1.1  | 493     | 298    | 791    | 493    | 345    | 839    | 5                |

Stainless Steel

| LPM | HP  | kW   | 3-Phase |        |        | 3-Wire |        |        | P.E. Weight (kg) |
|-----|-----|------|---------|--------|--------|--------|--------|--------|------------------|
|     |     |      | A (mm)  | B (mm) | C (mm) | A (mm) | B (mm) | C (mm) |                  |
| 70  | 1   | 0.75 | 395     | 298    | 693    | 395    | 298    | 693    | 4                |
|     | 1.5 | 1.1  | 488     | 298    | 786    | 488    | 345    | 834    | 5                |
|     | 2   | 1.5  | 612     | 345    | 958    | 612    | 384    | 996    | 6                |
|     | 3   | 2.2  | 913     | 407    | 1321   | 913    | 484    | 1397   | 7                |
|     | 5   | 3.7  | 1420    | 589    | 2009   | 1420   | 741    | 2161   | 12               |
|     | 7.5 | 5.5  | 1699    | 741    | 2440   | N/A    | N/A    | N/A    | 14               |

Note: P.E. – Pump end only  
 Product dimensions assume the FPS pump end is assembled to a 4" Franklin Electric submersible motor.  
 Maximum diameter with cable guard is 99.1 mm



# 50 Hz Tri-Seal



## 70 LPM Tri-Seal Performance Curves

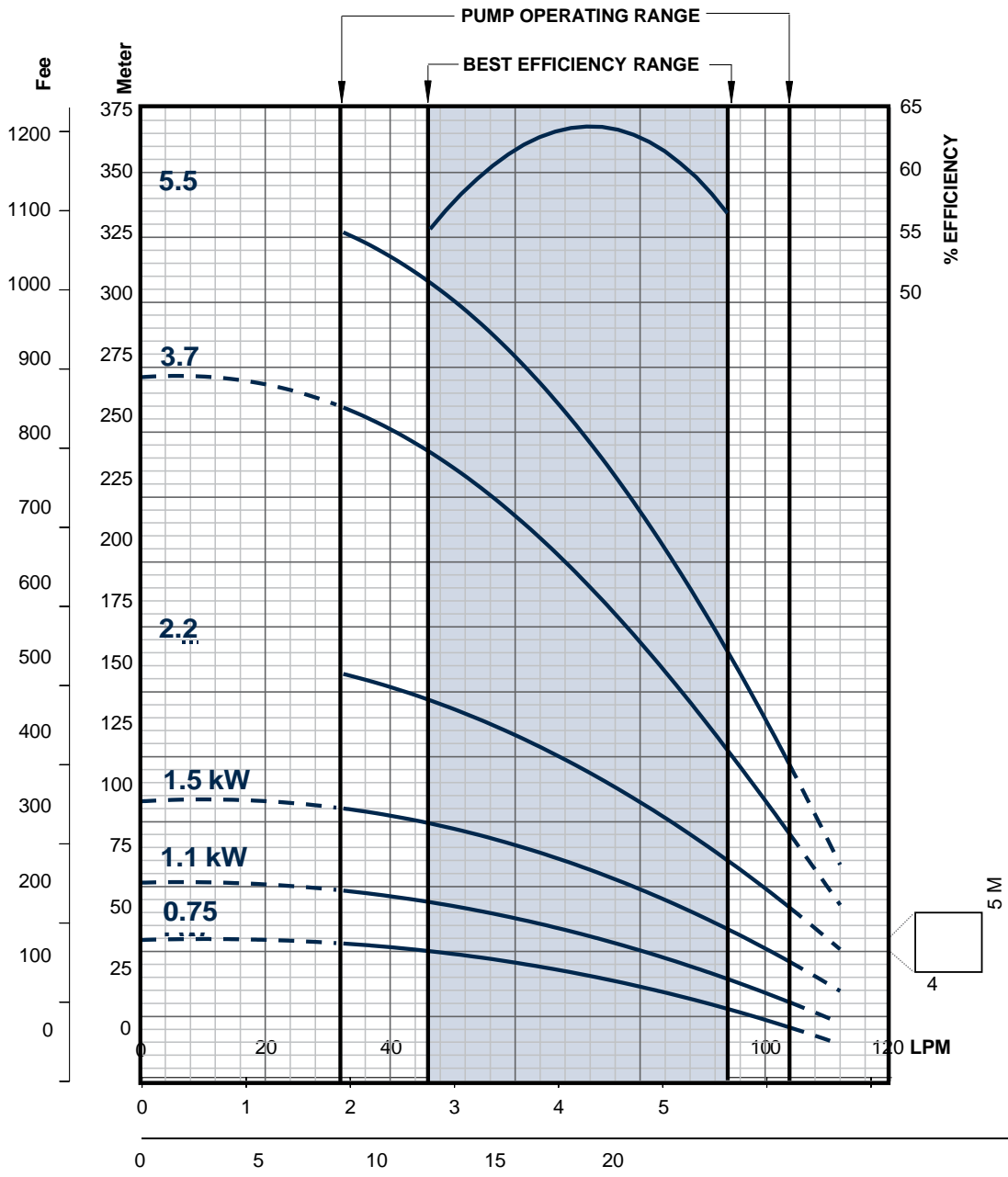



## 4400 High Capacity

The FPS 4400 High Capacity pump is engineered for commercial, irrigation and residential use. Design advancements reduce efficiency losses caused by internal pump leakage and abrasives.

### Features:

- 4 performance ranges: 100, 150, 200 & 270 LPM.
- Stainless steel discharge head and motor bracket.
- High flow impellers and stages are glass-filled Noryl for maximum efficiency.
- Ceramic shaft sleeve and rubber discharge bearing eliminates sand wear.
- Intermediate bearing for increased shaft stability.
- Floating eye and hub seals improve performance and efficiency.
- Stainless steel hex pump shaft, shell and shaft coupling.
- High capacity upthrust assembly for protection during start-up and operation (150, 200 & 270 LPM models).
- Powered by Franklin Electric's corrosion-resistant 4" submersible motor.
- 2" BSPP discharge threads.
- External check valve must be ordered separately.

# 50 Hz High Capacity

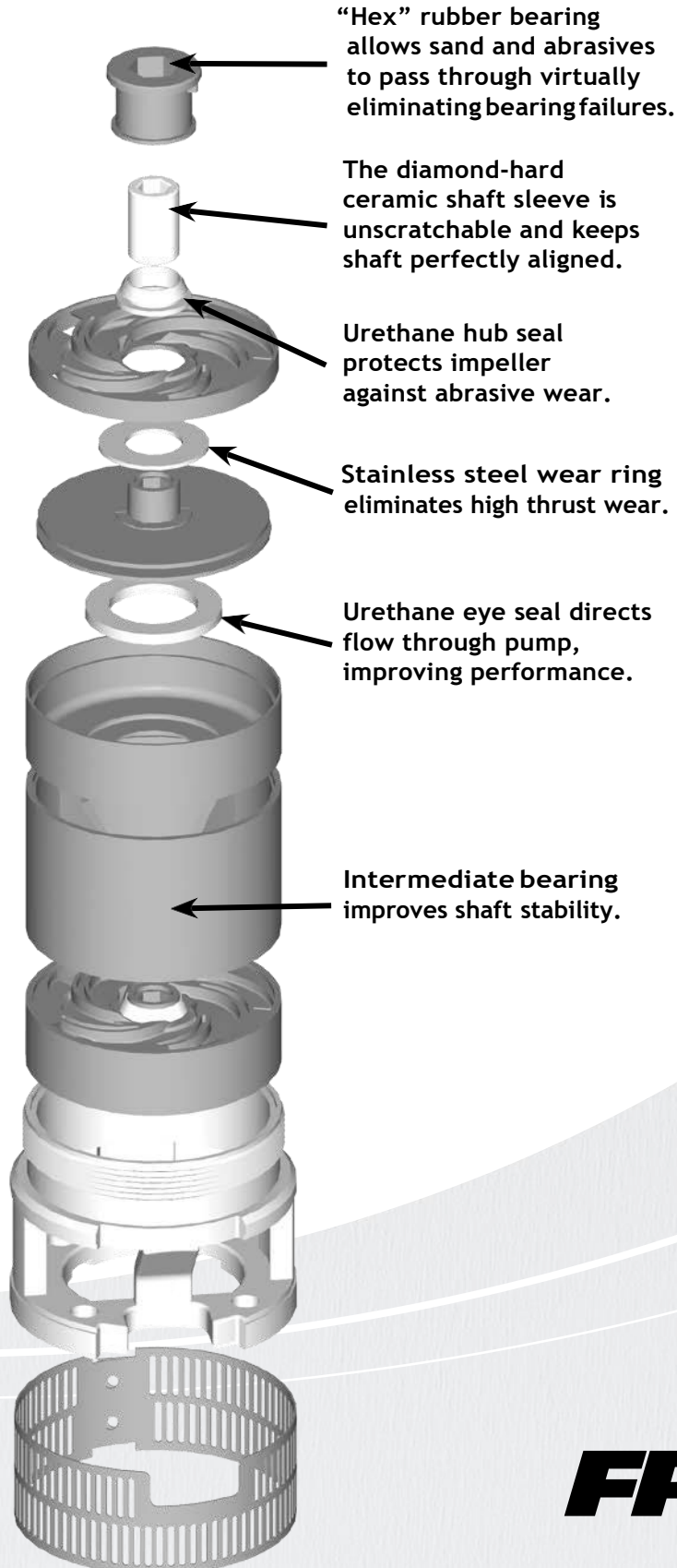

# **FPS** 4400

# 50 Hz High Capacity



## 100 LPM High Capacity

### 100 LPM Hi-Cap Ordering Information Stainless Steel

| LPM | HP  | kW   | Stages | Model Description | Order No. |
|-----|-----|------|--------|-------------------|-----------|
| 100 | 3/4 | 0.55 | 6      | 100FA07S4-PEXB    | 93616306  |
|     | 1   | 0.75 | 8      | 100FA1S4-PEXB     | 93616308  |
|     | 1.5 | 1.1  | 10     | 100FA15S4-PEXB    | 93616310  |
|     | 2   | 1.5  | 14     | 100FA2S4-PEXB     | 93616314  |
|     | 3   | 2.2  | 22     | 100FA3S4-PEXB     | 93616322  |
|     | 5   | 3.7  | 34     | 100FA5S4-PEXB     | 93616334  |
|     | 7.5 | 5.5  | 42     | 100FA7S4-PEXB     | 93616342  |

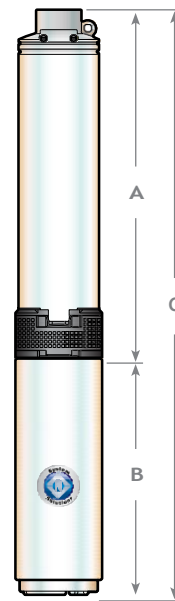

### 100 LPM Hi-Cap Dimensional Data Stainless Steel

| LPM | HP  | kW   | 3-Phase |        |        | 3-Wire |        |        | P.E. Weight (kg) |
|-----|-----|------|---------|--------|--------|--------|--------|--------|------------------|
|     |     |      | A (mm)  | B (mm) | C (mm) | A (mm) | B (mm) | C (mm) |                  |
| 100 | 3/4 | 0.55 | 382     | 298    | 678    | 382    | 298    | 678    | 4                |
|     | 1   | 0.75 | 446     | 298    | 742    | 446    | 384    | 828    | 5                |
|     | 1.5 | 1.1  | 510     | 346    | 853    | 510    | 384    | 892    | 5                |
|     | 2   | 1.5  | 638     | 488    | 1123   | 638    | 564    | 1199   | 5                |
|     | 3   | 2.2  | 893     | 564    | 1455   | 893    | 716    | 1607   | 6                |
|     | 5   | 3.7  | 1325    | 589    | 1914   | 1325   | 741    | 2066   | 12               |
|     | 7.5 | 5.5  | 1581    | 741    | 2322   | N/A    | N/A    | N/A    | 14               |

**Note:** P.E. – Pump end only  
 Product dimensions assume the FPS pump end is assembled to a 4" Franklin Electric submersible motor.  
 Maximum diameter with cable guard is 99.1 mm

# 50 Hz High Capacity



## 100 LPM High Capacity Performance Curves

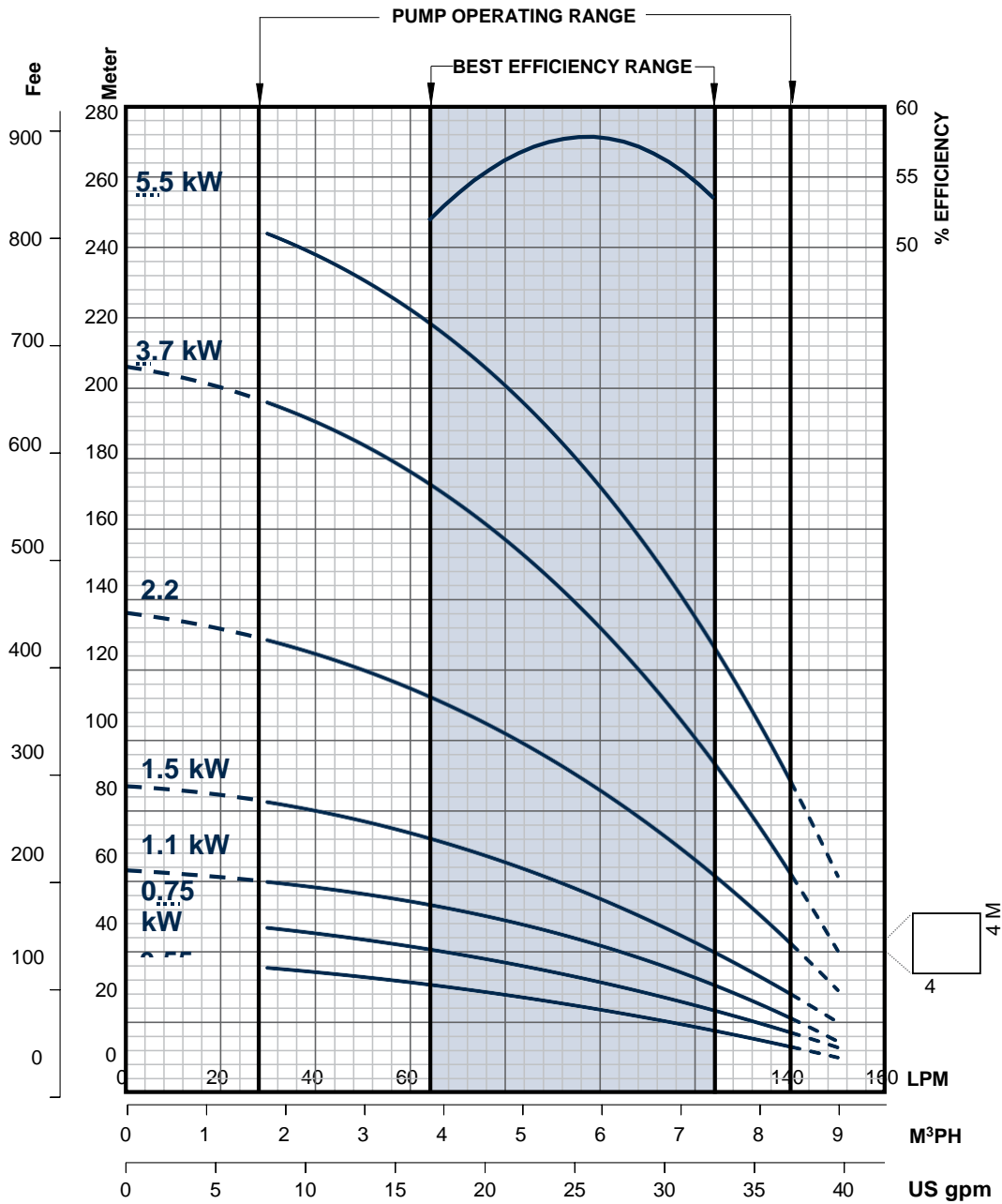

# 50 Hz High Capacity

## 150 LPM High Capacity

### 150 LPM Hi-Cap Ordering Information

#### Stainless Steel

| LPM | HP  | kW  | Stages | Model Description | Order No. |
|-----|-----|-----|--------|-------------------|-----------|
| 150 | 1.5 | 1.1 | 7      | 150FA15S4-PEXB    | 93616407  |
|     | 2   | 1.5 | 9      | 150FA2S4-PEXB     | 93616409  |
|     | 3   | 2.2 | 14     | 150FA3S4-PEXB     | 93616414  |
|     | 5   | 3.7 | 26     | 150FA5S4-PEXB     | 93616426  |
|     | 7.5 | 5.5 | 31     | 150FA7S4-PEXB     | 93616431  |

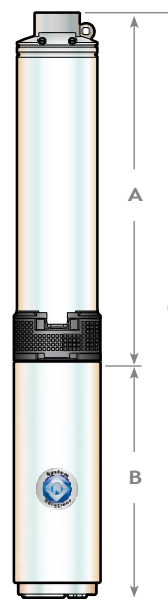

### 150 LPM Hi-Cap Dimensional Data

#### Stainless Steel

| LPM | HP  | kW  | 3-Phase |        |        | 3-Wire |        |        | P.E. Weight (kg) |
|-----|-----|-----|---------|--------|--------|--------|--------|--------|------------------|
|     |     |     | A (mm)  | B (mm) | C (mm) | A (mm) | B (mm) | C (mm) |                  |
| 150 | 1.5 | 1.1 | 593     | 298    | 891    | 593    | 384    | 977    | 5                |
|     | 2   | 1.5 | 707     | 346    | 1053   | 707    | 384    | 1091   | 5                |
|     | 3   | 2.2 | 993     | 513    | 1506   | 993    | 589    | 1582   | 6                |
|     | 5   | 3.7 | 1679    | 589    | 2268   | 1679   | 741    | 2420   | 8                |
|     | 7.5 | 5.5 | 1989    | 742    | 2731   | N/A    | N/A    | N/A    | 17               |

Note: P.E. – Pump end only

Product dimensions assume the FPS pump end is assembled to a 4" Franklin Electric submersible motor.

Maximum diameter with cable guard is 99.1 mm

# 50 Hz High Capacity



## 150 LPM High Capacity Performance Curves

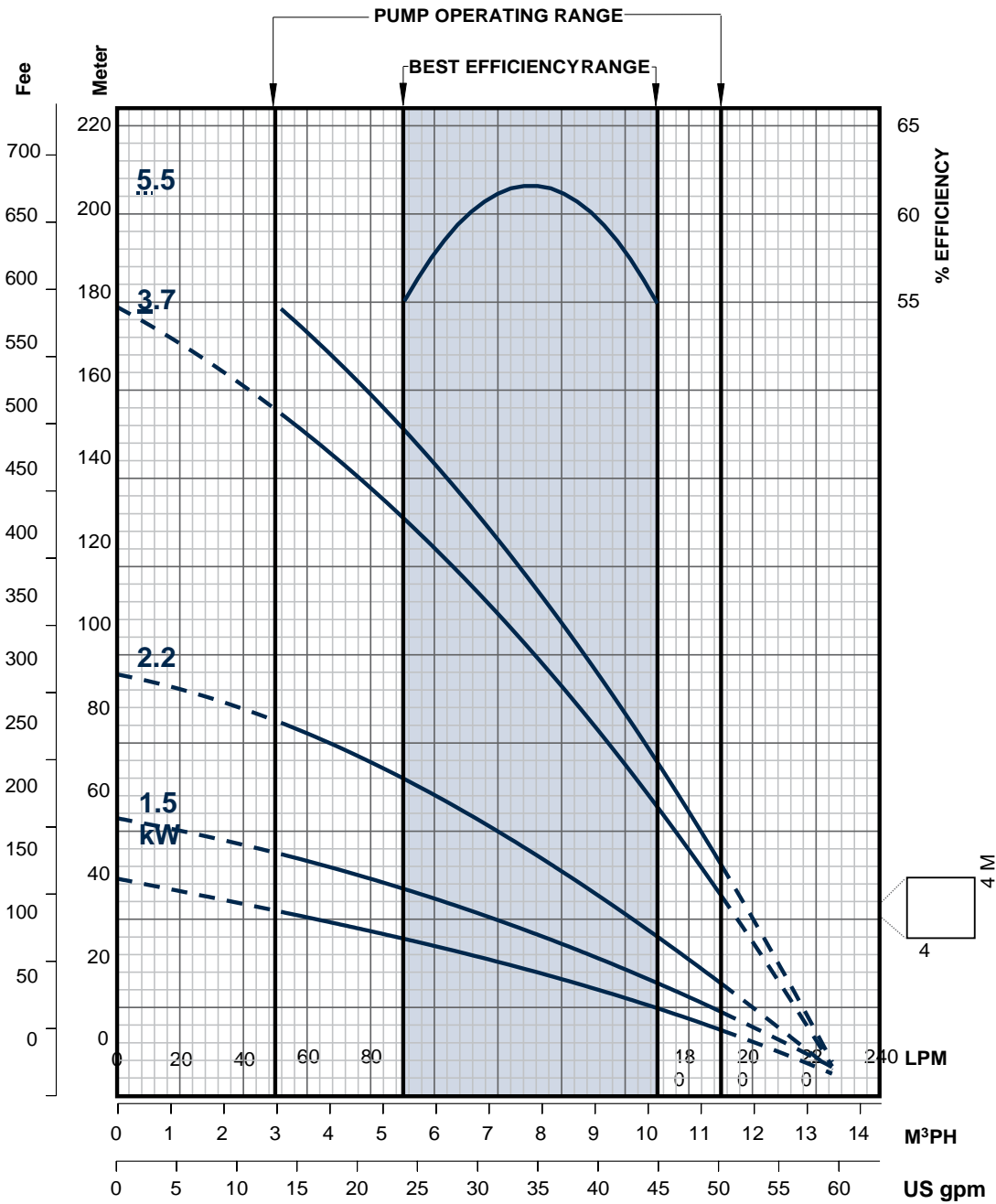

# 50 Hz High Capacity

## 200 LPM High Capacity

### 200 LPM Hi-Cap Ordering Information Stainless Steel

| LPM | HP  | kW  | Stages | Model Description | Order No. |
|-----|-----|-----|--------|-------------------|-----------|
| 200 | 2   | 1.5 | 6      | 200FA2S4-PEXB     | 93616606  |
|     | 3   | 2.2 | 9      | 200FA3S4-PEXB     | 93616609  |
|     | 5   | 3.7 | 17     | 200FA5S4-PEXB     | 93616617  |
|     | 7.5 | 5.5 | 26     | 200FA7S4-PEXB     | 93616626  |

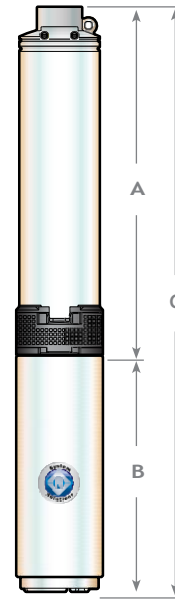

### 200 LPM Hi-Cap Dimensional Data Stainless Steel

| LPM | HP  | kW  | 3-Phase |        |        | 3-Wire |        |        | P.E. Weight (kg) |
|-----|-----|-----|---------|--------|--------|--------|--------|--------|------------------|
|     |     |     | A (mm)  | B (mm) | C (mm) | A (mm) | B (mm) | C (mm) |                  |
| 200 | 2   | 1.5 | 536     | 346    | 882    | 536    | 384    | 920    | 7                |
|     | 3   | 2.2 | 707     | 488    | 1195   | 707    | 564    | 1271   | 8                |
|     | 5   | 3.7 | 1164    | 589    | 1753   | 1164   | 741    | 1905   | 10               |
|     | 7.5 | 5.5 | 1679    | 741    | 2496   | NA     | NA     | NA     | 11               |

**Note:** P.E. – Pump end only

Product dimensions assume the FPS pump end is assembled to a 4" Franklin Electric submersible motor.  
Maximum diameter with cable guard is 99.1 mm



# 50 Hz High Capacity



## 200 LPM High Capacity Performance Curves

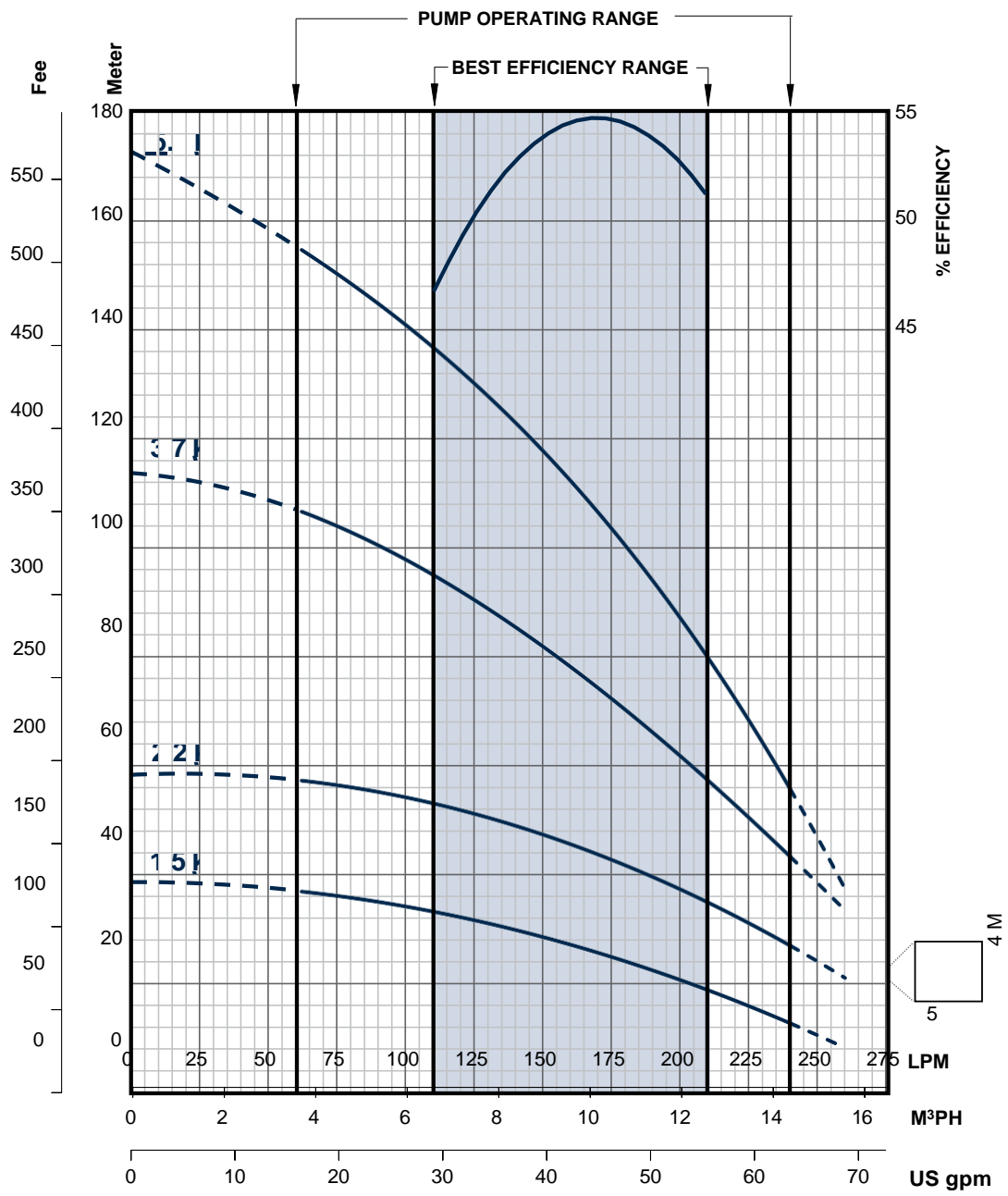

270 LPM High Capacity

270 LPM Hi-Cap Ordering Information  
Stainless Steel

| LPM | HP  | kW  | Stages | Model Description | Order No. |
|-----|-----|-----|--------|-------------------|-----------|
| 270 | 1.5 | 1.1 | 5      | 270FA15S4-PEXB    | 93616905  |
|     | 2   | 1.5 | 7      | 270FA2S4-PEXB     | 93616907  |
|     | 3   | 2.2 | 11     | 270FA3S4-PEXB     | 93616911  |
|     | 5   | 3.7 | 19     | 270FA5S4-PEXB     | 93616919  |
|     | 7.5 | 5.5 | 24     | 270FA7S4-PEXB     | 93616924  |

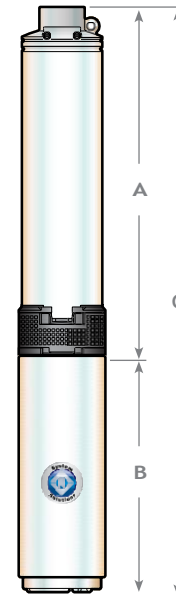

270 LPM Hi-Cap Dimensional Data  
Stainless Steel

| LPM | HP  | kW  | 3-Phase |        |        | 3-Wire |        |        | P.E. Weight (kg) |
|-----|-----|-----|---------|--------|--------|--------|--------|--------|------------------|
|     |     |     | A (mm)  | B (mm) | C (mm) | A (mm) | B (mm) | C (mm) |                  |
| 270 | 1.5 | 1.1 | 575     | 298    | 873    | 575    | 384    | 959    | 5                |
|     | 2   | 1.5 | 728     | 346    | 1074   | 728    | 384    | 1112   | 5                |
|     | 3   | 2.2 | 1033    | 513    | 1546   | 1033   | 589    | 1622   | 6                |
|     | 5   | 3.7 | 1641    | 589    | 2230   | 1641   | 741    | 2382   | 10               |
|     | 7.5 | 5.5 | 2012    | 741    | 2753   | NA     | NA     | NA     | 14               |

**Note:** P.E. – Pump end only  
Product dimensions assume the FPS pump end is assembled to a 4" Franklin Electric submersible motor.  
Maximum diameter with cable guard is 99.1 mm

# 50 Hz High Capacity



## 270 LPM High Capacity Performance Curves

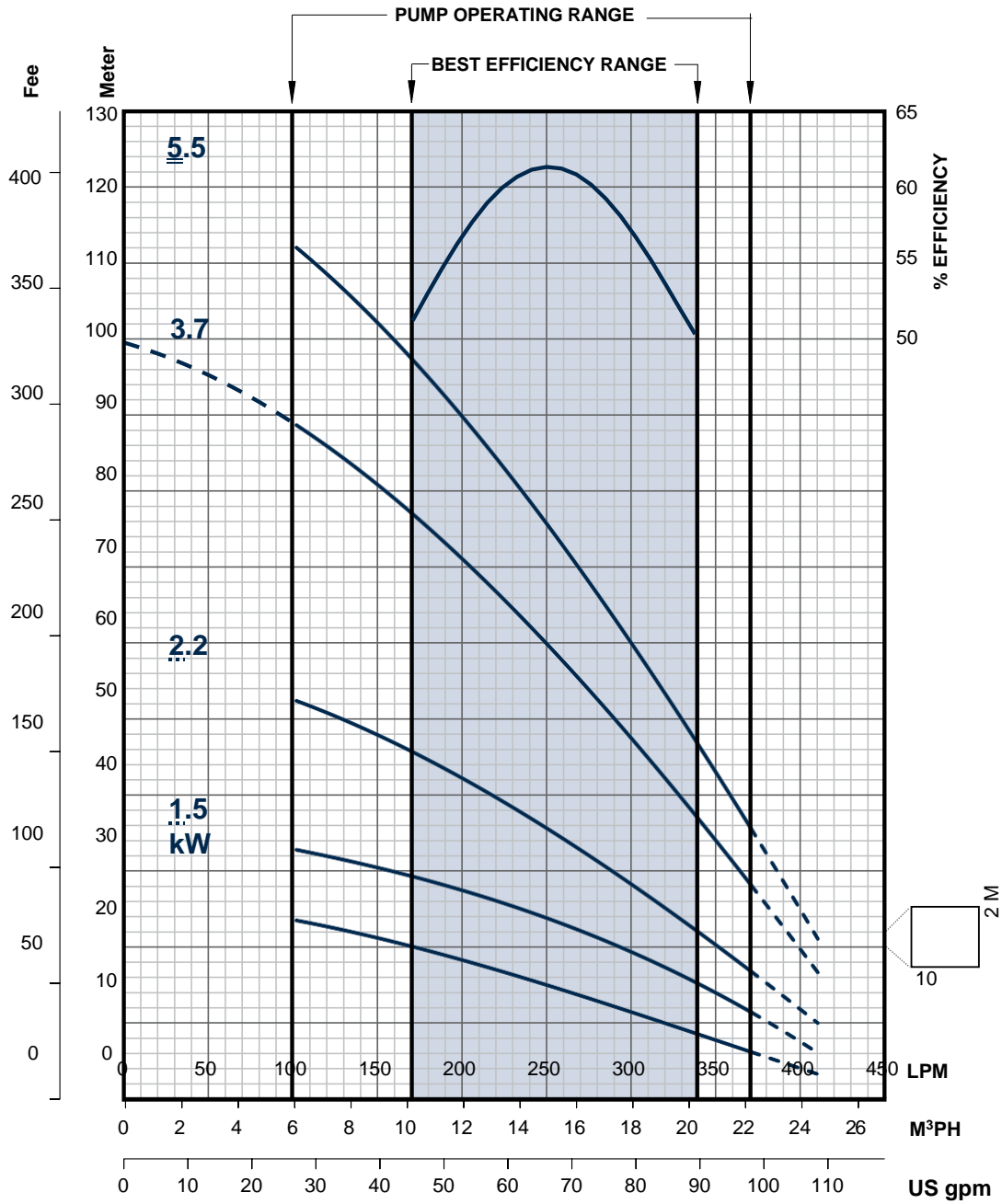

## **ASEAN**

Franklin Electric (SEA) Pte. Ltd.  
17 Changi Business Park Central 1  
# 06-05, Honeywell Building  
Singapore 486 073

Phone: +65.6789.6865  
Fax: +65.6789.0155

## **CHINA**

Franklin Electric (Shanghai) Co. Ltd.  
Unit 1002-03, Shanghai Central Plaza  
No. 227, Huang Pi Bei Road,  
Shanghai 200003, China

Phone: +86.21.6327.0909  
Fax: +86.21.6327.0910

## **INDIA**

Franklin Electric India Pvt. Ltd.  
DBS-206, 1st Floor  
World Trade Tower  
Barakhamba Avenue  
New Delhi 110 001, India

Tel: +91.11.4308.4697  
Fax: +91.11.2341.4740

## **AUSTRALIA / NEW ZEALAND**

Franklin Electric (Australia) Pty. Ltd.  
106 - 110 Micro Circuit  
Dandenong South, Victoria 3175  
Australia

Phone: +61.3.9799.5000  
Fax: +61.3.9799.5050  
Hotline: 1.300 FRANKLIN (1.300.372.655)

## **LATIN AMERICA**

Motores Franklin S.A. de C.V.  
Avenida Churubusco #1600  
(Bodega #16)  
Col. Francisco I. Madero  
Monterrey, N.L.  
Mexico C.P. 64560

Phone: +52.81.8000.1000  
Fax: +52.818.864.8445

## **UNITED STATES**

Franklin Electric Co., Inc.  
9255 Coverdale Road  
Fort Wayne, IN 46809 USA

Phone: +1.260.824.2900  
Fax: +1.260.824.2909

