

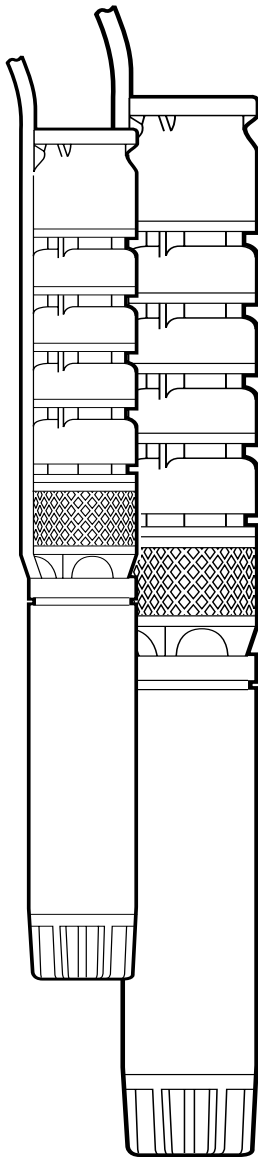

Franklin Electric

FS/FT Series - Borehole Pumps OWNER'S MANUAL



INTRODUCTION

The good functioning of the electric submersible pump, its reliability and lasting depend from the severe respect of the present notes and those concerning the electric motor by the installer and the end user.

Read carefully and take note of prescriptions, suggestions and indications necessary for a correct use.

On receipt of the electric submersible pump check that technical data reported on the identification plate correspond to the order.

Check, furthermore, that during transport the pump has not been damaged.

PURPOSE OF THIS MANUAL

The instructions for use contained in the present manual refer to the pump only. Therefore, for the use of the electric submersible pump, these instructions must be integrated with those of the manual of the electric submersible motor.

Keep this manual and any eventual further documentation in a suitable place easy to reach by the operators when necessary.

Eventual revisions and modifications will be made without previous notice.

STANDARD REFERENCES

This borehole electric pump has been studied and realized in compliance with: Machine Directive 98/37/CE.

Conformity will be no longer valid in case of modifications made on the machines without the acceptance of the manufacturer or in case of improper use or, in any case, not foreseen by the present manual, by the technical documentation or by the plate data.

SAFETY

Symbology

Exemplification of symbologies used for protection of persons, electric pump and relevant equipment:



DANGER

The non observance of the prescription involves the risk of damages to people and/or things.



TECHNICAL DANGER

The non observance of the prescription involves the risk of technical damages to the pump and / or installation.

Warnings

Operations reported in this manual, with particular reference to:

- transport
- installation
- electric and mechanical connections
- starting, operation and eventual maintenance or stop of service

Must be carried out by experienced personnel who well know the rules concerning safety of working environment and who has taken vision and carefully verified the content of this manual and of any other documentation enclosed to the product.



Before any intervention of checking or maintenance of the installation or electric equipment, it's indispensable to disconnect electric power supply being sure that same cannot be reconnected inadvertently.

Never tamper or remove installed protections and safety devices; when necessary, ask for intervention of competent personnel.

Be sure to operate in safety conditions with well dimensioned equipment and instrumentations complying with local safety regulations.

The acoustic level of electric submersible pumps, when correctly installed, does not reach 70 dB(A).

TECH. CHARACTERISTICS & USE

Technical description

The borehole electric pumps, driven by electric motor, are mainly used in deep wells for pumping underground waters.

The pumps are mixed-flow multistage centrifugal type with incorporated non-return valve on delivery and suction support fitted for coupling the motor, protected by suitable grid.

All pumps are supplied complete with stainless steel cable guard placed outside the pump body, for protection of the electric cable.

Use limits

The hydraulic coupled to the electric motor originates the "electric submersible pump" whose main applications are: irrigation, municipal water systems, civil, industrial and mining field, fire-fighting installations, thermoelectric centrals, artificial snowing... .

Use conditions

in standard execution this borehole electric pump is suitable to deliver even chemically aggressive water with maximum 70g/ m³ suspended solids.

As regards:

- Max. water temperature;
- Well dimension and minimum capacity necessary to motor cooling;
- Max. startings per hour;
- Electric and functioning characteristics;

Read instruction manual and technical documentation of the submersible motor.



In case of use in different conditions from the suggested ones or constructive modifications made without previous authorization, warranty foreseen in the general sale conditions will be no longer valid and the manufacturer will not be responsible of eventual damages caused to persons, animals or things.



Use limits

The pump is supplied complete with plates reporting the characteristic data: a plate is stuck outside the pump, while a copy of the same, contained in an envelope, is enclosed to the pump body for an easy consultation of the reported data, when necessary.

In case of request for warranty it's important to inform the manufacturer of all characteristic data.

HANDLING & STORAGE

Handling

To reduce risks during lifting and handling operations, be sure to operate in security conditions checking that equipments are complying with safety rules and suitable for the weight, dimensions and shape of the pump. Handle the pump with protective gloves avoiding cut risks to hands.



Before handling and lifting check: Weight of the pump (reported on the plate). The lifting hook position (fig. 2).

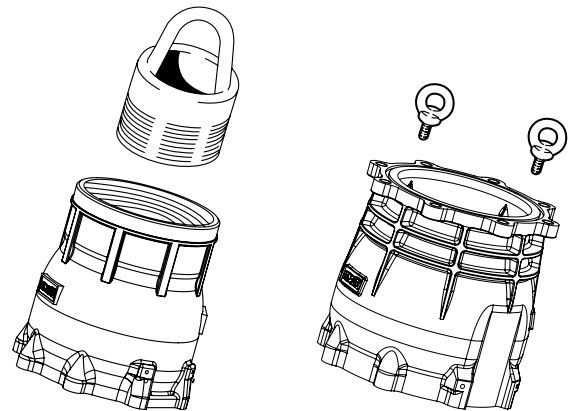

Fig. 2



When lifting and placing the pump be sure of its stability before releasing the lifting equipment (fig. 3).

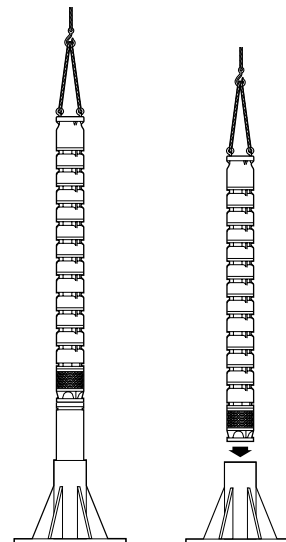

Fig. 3

Storage

Electric submersible pumps must be stored in covered, dry and well aerated rooms.



Keep the pump in vertical position by suitable anchor clamps checking its stability in order to avoid dangerous falls (fig. 4).

In case of long storage, protect with grease the motor coupling flange against oxidation and rotate periodically by hand the shaft to avoid possible locking of the same.

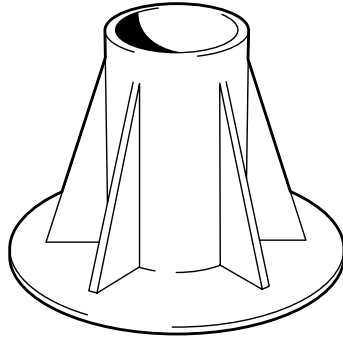

Fig. 4

INSTALLATION

Inspections before installation

Before installation of the electric submersible pump proceed as follows:

- check that implements (ropes, belts, chains etc.) and equipment (winch, crane, hoist, gin etc.) to be used for handling, lifting and positioning the pump in the well, are well dimensioned to the weight, efficient and complying with safety norms.
- check right dimensions of the well, its straightness and dynamic level.
- verify water quality, its temperature and eventual presence of sand, mud and dissolved gas.
- verify that rated motor power is equal or higher than the max. power absorbed by the pump and that the main electric network has sufficient power.
- check efficiency of probes against dry functioning.
- verify that pump rotates in the same direction of the motor.

Motor-pump coupling

Flanges and shaft projection

This electric submersible pump is fitted to be coupled to submersible motors with flange and shaft projection:

- complying with Nema norms for 6" – 8" motors
- according to different drawing for motors ≥ 10 ".

For motor/pump coupling follow scrupulously both instructions concerning the pump and the motor.

Inspections for coupling and rotating direction



Before coupling be sure that motor data plate corresponds to pump data and that also flange and shaft extension coincide.

Verify that motor and pump rotate in the same direction.

Coupling

Proceed as follows:

- make use of protective gloves.
- verify that the rotor of motor and pump shaft are turning free by hand. If you make use of standard implements like pliers, screwdrivers or pins, protect coupling surfaces by suitable tape to prevent damages.
- clean carefully surfaces to be coupled, smoothing when necessary and removing eventual excessive paint.
- place the motor in vertical position checking its stability during the whole coupling operation.
- using the suitable equipment (mobile crane, hoist, etc.), lift the pump and when perfectly vertical over the motor lower it slowly taking care that the motor shaft enters freely into the pump coupling (fig 5). Safeguard your hands during this operation!
- pilot coupling keeping the hands outside the pump, far from flanges.
- verify that electric cables of the motor are in correspondence with relevant pump seats.

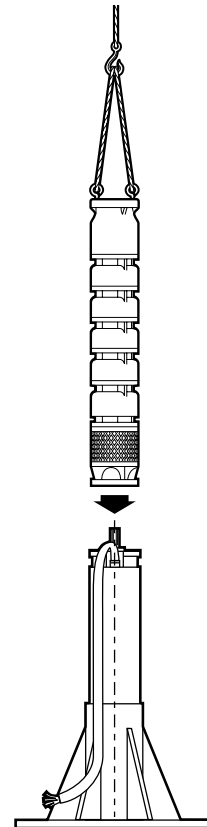

Fig. 5

In case of motors with splined shaft projection, we suggest to lubricate the coupling splines with a light coat of antipollution and waterproof grease against wearing due to the eventual presence of sand.

- screw diagonally securing screw, possibly by dynamometric spanner (fig. 6), at the following values:

6" motor	driving torque = 60 Nm	45 lb. -ft.
8" motor	driving torque = 140 Nm	100 lb. -ft.
10" motor	driving torque = 200 Nm	150 lb. -ft.
12" motor	driving torque = 280 Nm	205 lb. -ft.

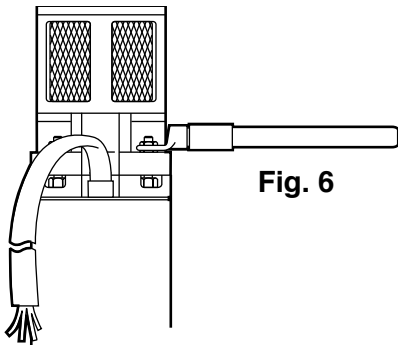

Fig. 6

- adjust electric cables outside the pump and cover them by the suitable guard (fig. 7).

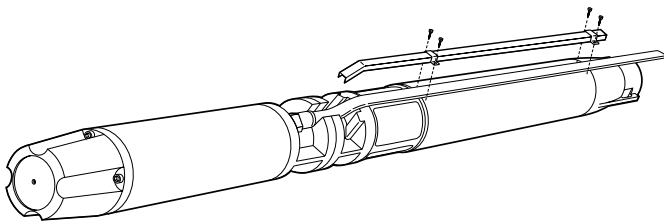

Fig. 7



Should the assembled group exceeds lengths "L" indicated on the table no.1, for positioning it horizontally or lifting it again vertically, make use of an auxiliary support for preventing possible damages which might be caused by bending stress (fig.8).

Ø group	Max. "L" Length
6"	3,3 m
8"	3,5 m
10" - 12" - 14"	4,0 m

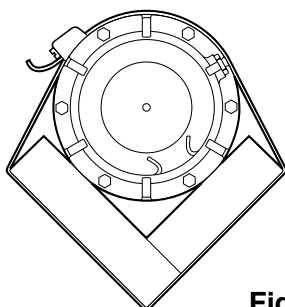
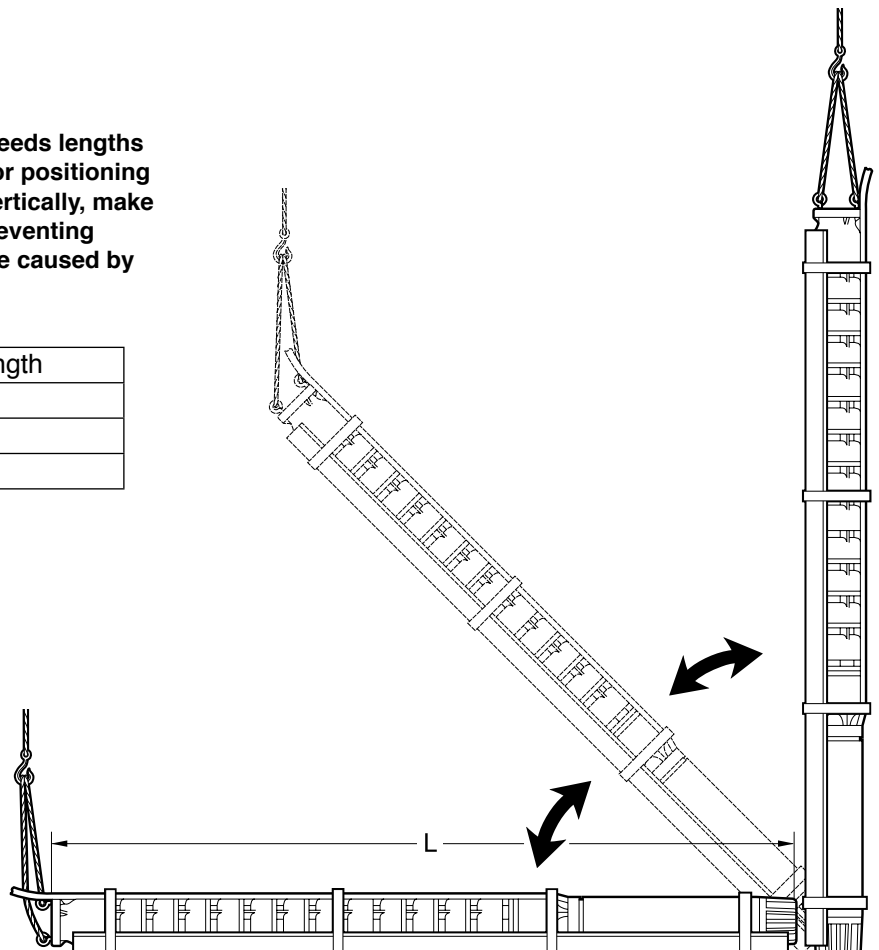

Fig.8



Installation of the group Precautionary inspections

For installation follow scrupulously pump and motor instructions.



Check that lifting equipment comply with safety rules and suitable to support the weight of the group plus the weight of pipeline, valves and cables.



In case of lifting out the group from the well, remember to add to above loads the weight of the water contained in the pipeline by the non-return valve of the pump.

Verify that the well is straight and enough dimensioned to guarantee a correct installation of the electric pump.



Verify that water characteristics and dynamic level are in the foreseen limits and that well has been perfectly cleaned from sand and other debris.



Should the assembled group exceeds lengths stated on table no.1, for lifting it vertically, make use of an auxiliary support for preventing possible damages which might be caused by bending stress (fig. 8).

Installation in deep well

Lower the electric pump into the well taking care not to damage either the electric cable nor the level relay cables (fig. 9).

In case of flanged pipeline, flanges should be equipped with suitable slots for cable passage in order to avoid damages. Don't forget to insert among flanges relevant gaskets.

In case of threaded pipes, assemble firstly the upper threaded sleeve and than the supporting clamp in order to avoid a dangerous disengagement of the rising pipe from the assembling bracket.



When using plastic pipeline it's necessary to support permanently the group by suitable antiwear inextensible cables (plated steel – stainless steel – polyester etc.).

Each 2-4 meter fasten the electric cables to the rising pipe using the suitable waterproof clamps (fig. 9 pos. 10).

During the lowering of the electric pump in the well, measure the insulation resistance following the notes indicated in the motor manual.

The installation is completed when the regulating valve and the non-return valve are mounted and the electric pump is on the following functioning conditions (fig 9):

- positioned at least 2 mt from the bottom of well (height C)
- positioned at least 1 mt (height D) above the well suction strainer; this is essential to ensure motor cooling (see motor cooling conditions)
- with dynamic level of water (height B) at least 2 ÷ 2,5 mt above the suction strainer of the pump. The dynamic level should, in any case, satisfy the NPSH required by the pump.

Consider attentively the problems due to the seasonal dropping of water table and to the excessive pumping in comparison with the well capacity.

1	- Electric pump
2	- Electric panel
3	- Gate valve
4	- Pressure gauge
5	- Non-return valve
6	- Electrodes for water level control
7	- Well grid
8	- Well bottom
9	- Main electric cable
10	- Cable clamps
11	- Well cover
A	- Static level
B	- Dynamic level
C	- Distance from bottom of well
D	- Distance from grid of well

Fig.9

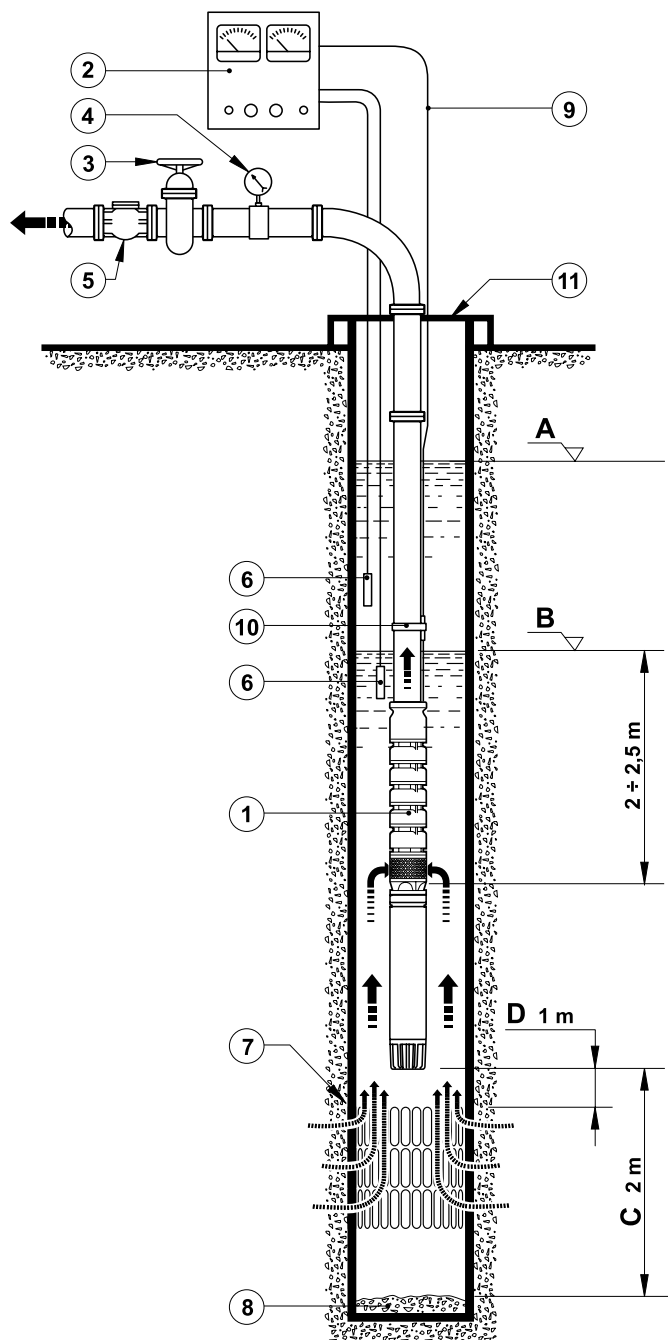

USE & MAINTENANCE

Starting

For starting operations refer to the instructions indicated on the motor manual.

Before starting the electric pump carry out a final check on the hydraulic connection and on the electrical equipment and relevant ratings.



Activate all safety procedures foreseen and check attentively the efficiency of protections. When the electric pump is installed into wells of particular depths, the column pipe must be filled with water before running, to avoid the consequences coming from the rotor rising during starting.

If the electric motor is fitted for rotating in both directions, start the electric pump with gate valve slightly opened in order to check the correct rotation according to pressure indicated on the pressure gauge. If rotation is correct, the pressure gauge will indicate the same pressure shown on the catalogue to a nearby 0 delivery. Worthy to remind that the height between pressure gauge and dynamic level must be added to the pressure value readable on the pressure gauge.

If rotation is wrong, pressure will be much lower, but the absorbed current might be higher than the foreseen. To invert rotation in three-phase motors swap over two of the phase wires.



Never let pump functioning in wrong direction for more than 3-4 minutes.

If the electric motor is fitted for rotating in one direction only for the correct electric connection refer to instructions indicated on the motor manual; even in this case starting must be done with gate-valve slightly open.

With the pump functioning, gradually open the gate-valve up to reach the required performances, checking with an amperometer, that the current absorbed does not exceed the value shown on the motor plate. If necessary lower the current absorbed (Amperes) below the value shown on the motor plate, reducing the capacity closing the gate-valve and, afterwards, setting the protection relays accordingly.



The relay setting should never exceed the value indicated on the motor plate.

Check that the capacity obtained is according to the cooling conditions of electric motor.



Never let pump functioning with 0 capacity (gate-valve closed) for more than 2-3 minutes.

On first startings of electric pump, it's necessary to check that the pumped water is not cloudy with sand or lime. In the affirmative, it's necessary to reduce immediately the pump capacity, closing the gate-valve, until the water is clear. This situation must be obtained in a short time, max. 8-10 min.; on the contrary, to avoid heavy damages to the pump, it's necessary to effect a further cleaning of the well using a pump suitable to this purpose.

Functioning

When respecting foreseen functioning limits the electric pump will operate without vibrations or anomalous noises.



Keep the hydraulic (capacity – pressure) and electric working conditions within the values shown on the plate (please refer to par. 3-4).

Incorrect installation or unsuitable use always causes failure undue wears and dangerous damages. Every 1000 hours approx. of functioning it's necessary to check that operating data are respected; in case of anomalies or variations of operating data refer to par. 8 following relevant suggestions. Refer to information reported on the manual of the electric motor too.

Maintenance and spare parts

When respecting foreseen functioning limits, ordinary maintenance of the electric pump is not necessary.



Extraordinary maintenance and repairing must be carried out by qualified and skilled personnel.

Original spare parts only must be used. For lifting out the electric pump from the well proceed on the contrary of what stated for installation (see par. 5). Always follow safety conditions (par. 2)



Before any intervention of checking or maintenance it's indispensable to disconnect electric power supply being sure that same cannot be reconnected inadvertently; hearth cables must be disconnected at the last.

When ordering spare parts indicate the following:

- 1) type of pump
- 2) serial number
- 3) position and denomination of parts
- 4) quantity.

DEFECTIVE FUNCTIONING

PROBLEMS	PROBABLE CAUSES	REMEDIES
The borehole electric pump works but does not deliver water	Lack of water or well level too low	check level and relay efficiency
	Bored delivery pipe-line or connection leakages	Disassemble, repair or replace defective parts
	Sanded pump	Disassemble, clean, drain the well and evaluate convenience of rising the level of the pump
	Suction grid obstructed by straw, leaves or plastic	Very causes and clean
	Closed gate-valve	Open the gate-valve
	Blocked non-return valve	Disassemble, repair or replace
	Anticlockwise rotation (only for 3-phase electric pumps)	Invert rotation direction. See instructions at par. 6.1
	Insufficient pressure of the pump	Replace the electric pump with another of higher performances
	Damaged hydraulic components	Disassemble and replace damaged components
	Breakages of: pump shaft, motor shaft or coupling	Disassemble and replace broken components
Insufficient capacity and head	Anticlockwise rotation (only for 3-phase electric pumps)	Invert rotation direction. See instructions at par. 6.1
	Considerable lowering of the dynamic level	Apply skilled well drillers or replace the pump with another of higher performances
	Suction grid partially obstructed	Verify causes and clean
	Obstructed or partially blocked non-return valve	Lift out the electric pump, clean, repair or replace defective components
	Delivery pipe-line squashed, bent or heavy incrusted	Disassembly, clean or replace
	Bored delivery pipe-line or connection leakages	Disassembly, clean or replace
	Air or other gas dissolved in the water	Apply competent well drillers
	Worn hydraulic components of the pump	Lift out the elec. pump and repair. Caution!! Follow scrupulously what foreseen by warranty conditions
Vibrations and noise	Presense of gas in the pumped liquid	Apply competent well drillers
	Wearred bushes and/or bearings	Disassembly and replace wearred parts
	Excessive presense of sand or gravel	This condition causes heavy damages. See par. 6.1
	Entry of air into the pump due to variation of level	Reset dynamic level height and reduce capacity. See par. 5.3

Other functioning defects might be due to electrical or instrumental causes, to quality and temperature of the pumped water, etc. To verify causes and remedies refer to suggestions given by the manufacturer of the electric submersible motor.

ASEAN

Franklin Electric (SEA) Pte Ltd.
Singapore Representative Office
1 Changi Business Park Avenue 1
03-01, Ultro Building
Singapore 486058

Phone: +65.6789.6865
Fax: +65.6789.0155

CHINA

Franklin Electric (Shanghai) Co. Ltd.
Unit 1002-03, Shanghai Central Plaza
No. 227, Huang Pi Bei Road,
Shanghai 200003, China

Phone: +86 21 6327 0909
Fax: +86 21 6237 0910

AUSTRALIA / NEW ZEALAND

Franklin Electric (Australia) Pty. Ltd.
106 - 110 Micro Circuit
Dandenong South, Victoria 3175
Australia

Phone: +61.3.9799.5000
Fax: +61.3.9799.5050
www.franklin-electric.com.au

LATIN AMERICA

Motores Franklin S.A. de C.V.
Avenida Churubusco #1600
(Bodega #16)
Col. Francisco I. Madero
Monterrey, N.L.
Mexico C.P. 64560

Phone: +52.81.8000.1000
Fax: +52.818.864.8445

UNITED STATES

Franklin Electric Co., Inc.
400 E. Spring St., Bluffton, IN 46714 USA
Tel: +1.260.824.2900 Fax: +1.260.824.2909

